



*Cathodic Protection
Monitoring System*

CPMS

User's Manual

All product names are registered trademarks of their respective companies.

Table of Contents

Introduction	4
About this Manual	4
The CPMS	4
Discrete Inputs	5
On-Board Input Modules	5
Specifications	6
CPMS Dimensions	7
Connecting the CPMS to the Network	12
Ethernet Connection	12
MODBUS Connection	12
Configuring Ethernet Settings	13
CPMS Web Server	14
MODBUS Configuration	16
Configuring the CPMS as MODBUS Master	17
Configuring the Data Logger	19
CPMS Security	21
Changing the Security Settings.....	21
Resetting Interface Module Passwords	21
User Accounts.....	22
Hot-Swapping an I/O Module	23
On-Board Input Module Configuration	24
Cathodic Input Module	25
Voltage Input Module	25
AIM Analog Input Module	27
TIM Temperature Input Module	32
AOM Analog Output Module	38
CPM NET Concentrator System Power Module	43
DIM Discrete Input Module	46
ROM Relay Output Module	50
Loading a Custom Curve File	55
File Management	56
MODBUS RTU / TCP Support	57
Accessing Real-Time Data via MODBUS RTU / TCP	57
Data Conversion.....	58
Register Addressing.....	59
MODBUS Register Definitions Tables	59
CPMS Module Status Tables.....	62

Installation	67
Mounting	67
Making the Electrical Connections.....	67
Operation	68
Maintenance.....	68
Warranty	73

CPMS

Cathodic Protection
Monitoring System

Introduction

This is the user's manual for the Moore Industries Cathodic Protection Monitoring System (CPMS). The CPMS monitors cathodic protection systems to help ensure that proper corrosion protection is in place and operating at correct levels.

The Cathodic Protection Monitoring System is a part of Moore Industries' Net Concentrator System® (NCS) family of products. It embeds the Ethernet and MODBUS capabilities of our Ethernet MODBUS Interface Module (EMM) with four or eight analog and four discrete input channels.

CPMS Input/Output (I/O) capability can be extended by connecting one or more I/O modules to the integrated DB-25 connector.

The CPMS Interface Module provides power for up to two I/O Modules regardless of whether they are on-board or external modules. If two on-board modules are ordered on the CPMS, then power will be used by those modules. If a CPMS is comprised of one on-board input module, power will be provided for it and one more external module. If more than two I/O Modules will be connected to the Interface Module, a CPM Concentrator Power Module is required. It works in conjunction with the CPMS to power stations of up to eight I/O Modules.

A fully populated CPMS system can contain a maximum of 16 modules. This includes one or two on-board modules (specified by the customer at time of order) with the rest comprised of externally mounted I/O modules.

Note:

The terms Interface Module and CPMS are used interchangeably throughout this manual.

About this Manual

Wherever you see a "**Note**", "**Caution**" or "**WARNING**" pay particular attention.

- A "**Note**" provides information to help you avoid minor inconveniences during calibration, installation or operation of the instrument.
- A "**Caution**" provides information on steps to take in avoiding procedures and practices that could risk damage to the instrument or other equipment.
- A "**WARNING**" provides information on steps to take in avoiding procedures and practices that could pose safety risks to personnel.

The CPMS

The CPMS monitors instrumentation from one or two cathodic protection systems and makes data available through MODBUS polling.

The CPMS has a sufficient number of on-board inputs to monitor two cathodic protection systems. It continuously scans these inputs (and those of any attached I/O modules) and maintains a real-time database which also includes diagnostic data. Real-time data is accessible to a MODBUS master via MODBUS TCP through the Ethernet port or via MODBUS RTU through either RS-485 port.

The CPMS has an on-board real-time clock to provide time stamped data. Alternatively more accurate time can be achieved using a built in GPS module (-GPST option) or using SNTP to connect to a network time server. The CPMS can also act as a network time server (with firmware version 4.4 and later).

A user-configurable data logger stores up to 64,000 total samples in a circular First In, First Out (FIFO) buffer in RAM. The most recent 18,000 samples are stored in battery-backed RAM. The data log is accessible as a .csv file (Microsoft® Excel compatible) via Ethernet interfaces.

Discrete Inputs

Contact Closure (Discrete Inputs)

The CPMS is equipped with four contact closure inputs with a rating of 24V@3.7mA, internally powered. Refer to Table 3 for a description of these inputs.

On-Board Input Modules

A total of two on-board modules, of the same configuration, may be ordered on the CPMS. These consist of Current Input Modules and Cathodic Input Modules.

Current Input Module (Specified per customer)

Per customer order, an interface module may be ordered with one or two internal, on-board current input modules. Refer to Tables 4 and 5 for details of inputs.

Voltage Input Module (Specified per customer)

Per customer order, an interface module may be ordered with one or two internal, on-board voltage input modules. Refer to Tables 4 and 5 for details of inputs.

Cathodic Input Module (Specified per customer)

Per customer order, an interface module may be ordered with one or two internal, on-board cathodic input modules. Refer to Tables 4 and 5 for details of inputs.

The CPMS includes one or two on-board modules consisting of four inputs each. The number of on-board modules is designated by the customer at the time an order is placed for a CPMS.

When all four inputs of the on-board module are 4-20mA, this is a Current Input Module. The reference and label on the unit read Module x (where x refers to the module block, either 1 or 2). Refer to Tables 4 and 5 for inputs.

The second type of module is a Cathodic Input Module. This module is comprised of a complete cathodic input which includes inputs of: 0-100V, 0-100mV, -5 to +5V and 4-20mA. Refer to Tables 4 and 5 for inputs.

The third type of module is a Voltage Input Module. This module is comprised of one (1) 0-100V channel and three (3) channels of 0-100mV. Refer to Tables 4 and 5 for inputs.

Installation

Module numbering on the configuration web pages will vary depending on the number of on-board modules installed on your CPMS.

When installing external I/O modules to an Interface Module with one on-board Module (Current, Voltage or Cathodic Input), the first external module will appear as Module 2 on the configuration pages. The rest of the external modules will continue in numeric order (Modules 3, 4, 5 and so on).

If installing an external module to a CPMS with two on-board Modules (Current, Voltage or Cathodic Input), the first external module will appear as Module 3 on the configuration pages. The rest of the external modules will continue in numeric order (Modules 4, 5, 6 and so on).

CPMS

Cathodic Protection
Monitoring System

Specifications

Communications

ETHERNET

Ethernet Port:

10/100Base-T supports speeds up to 100Mb/second. Standard RJ-45 Connection Auto negotiation, Auto MDIX, DHCP or fixed IP address
Protocol Type: MODBUS/TCP

MODBUS:

Type: Two independently configurable RS-485 ports (according to EIA-485, 1993)

Protocol Type: MODBUS RTU

Baud Rates: 1200, 2400, 4800, 9600, 19.2k, 38.4k and 57.6k (userselectable; default is 9600)

Parity: Even, Odd or No Parity

(1 stop bit, fixed; default is No Parity)

Device Address: 1-255 (Default is 1)

Character Timeout: 5, 10, 25, 50, 100, 200 and 255 character times (user-selectable; factory set to default)

Response Delay: 1-255 character times (user-selectable; factory set to default)

Discrete Inputs:

Contact Closure: 24V@3.7mA, internally powered

Input Logic Threshold: 8V lowgoing; 16V high-going

Maximum Input Over Range: 24Vdc

Signal Response Time: 15mS

Performance

Analog Inputs:

Input Accuracy: Current, $\pm 0.1\%$ of 20mA span; Voltage, $\pm 0.1\%$ of maximum span

Stability: Refer to Table 1

Filter Configuration:
50/60Hz rejection selection (user-selectable)

Input Channel Update Time: 150msec

Data Access Time: Time to detect or effect a change in an I/O signal from a MODBUS master polling a CPMS is the sum of 3 timing components:

1. Network Communication Time: Depends on network architecture and traffic. For a PC locally networked to a CPMS, this time is negligible
2. Scan Time: Time required by the CPMS to scan real-time data in all I/O modules connected to it (see *Module Scan Time* specification for each I/O module type and add times for each I/O module connected to the CPMS)
3. Signal Response Time: Time to convert between physical I/O and digital signals (see specification for specific I/O type)

Isolation: 1000Vrms between case, input, output, each MODBUS port, each discrete input channel and power, continuous, and will withstand a 1200Vac dielectric strength test for one minute (with no breakdown). 500Vrms between analog input channels.

Power Supply:

24Vdc, 20-30Vdc; Uac, 90-260Vac

Power Consumption: Vdc, 7.0W maximum; Uac, 8.0W maximum

Input Impedance: Current, 20 ohms, nominal; Voltage, 10 Mohms, nominal

Maximum Input Over Range:

Current inputs, $\pm 100\text{mA}$, maximum; 0 to 100mV inputs, $\pm 250\text{Vdc}$, maximum; -5 to 5V inputs, $\pm 200\text{Vdc}$, maximum; 0 to 100V inputs, 200Vdc, maximum

Diagnostic Data: Refer to Installation Manual

Status and Fault Indicators

System:

READY: Green when ready;

Off when not ready; Red during CPU reset

STATUS: Green when OK;

Red when not OK

Ethernet:

Firmware Version 5.0.00 or greater

LINK/ACT: This LED indicates transmit and receive activity in addition to the status of the Link. The LED will be ON when Link is good. It will blink when the transmitter or receiver is active.

SPEED: This LED is ON when the Ethernet connection is 100 Mb/s and OFF when it is 10 Mb/s.

Firmware version prior to 5.0.00:

LINK: Amber LED indicates a network link is present

ACT: Flashes green in response to data reception and transmission

MODBUS:

TX1: Green blinks when Transmit activity on MODBUS 1 occurs; Off when no Transmit activity on MODBUS 1

RX1: Green blinks when Receive activity on MODBUS 1 occurs; Off when no Receive activity on MODBUS 1

TX2: Green blinks when Transmit activity on MODBUS 2 occurs; Off when no Transmit activity on MODBUS 2

RX2: Green blinks when Receive activity on MODBUS 2 occurs; Off when no Receive activity on MODBUS 2

TX: Green blinks when Transmit activity on Remote COM occurs; Off when no Transmit activity on Remote COM

RX: Green blinks when Receive activity on Remote COM occurs; Off when no Receive activity on Remote COM

DCD: Green when Remote COM connection is established;

Off when no Remote COM connection is present

DTR: Green when modem/GSM/radio connection is active and status is OK; Off when no modem/GSM/radio connection active; Red blinks when radio alarm is occurring.

System Time Accuracy

Real Time Clock (RTC):

± 1 Minute/Month (when not connected to an authoritative time source)

SNPT/GPS: <100ms of authoritative time source

Data Logger

Records up to 64,000 timestamped data points; minimum sample period, 100msec; maximum sample period, 24 hour Non-volatile memory holds timestamped data; measurement parameters are software configurable; 18,000 data points stored in BBRAM

Ambient Conditions

Operating Range:

-40°C to +85°C
(-40°F to +185°F)

Storage Range:

-50°C to +100°C
(-58°F to +212°F)

Relative Humidity:

0-95%, non-condensing

Ambient Temperature Effect:

100ppm of full scale/°C

RFI/EMI Protection:

20V/m@80-1000MHz, 1kHz
AM when tested according to EN61326 with errors of 0.5% or span or less

Noise Rejection: Common

Mode: 100dB@50/60Hz; Normal
Mode: Refer to Table 2

Weight

1.26 kg (44.3 oz)

Table 1. Long-Term Stability

Input	Error (% of maximum span)		
	1 Yr	3 Yrs	5 Yrs
Current Inputs	0.08	0.14	0.18
Voltage Inputs	0.09	0.16	0.21

Table 2. Normal Mode Rejection Ratio

Input	Max. p-p signal injection for 60dB at 50/60Hz
Current	20mA
0 to 100mV	10mV
-5 to 5V	1V
0 to 100V	10V

Figure 1. CPMS Dimensions

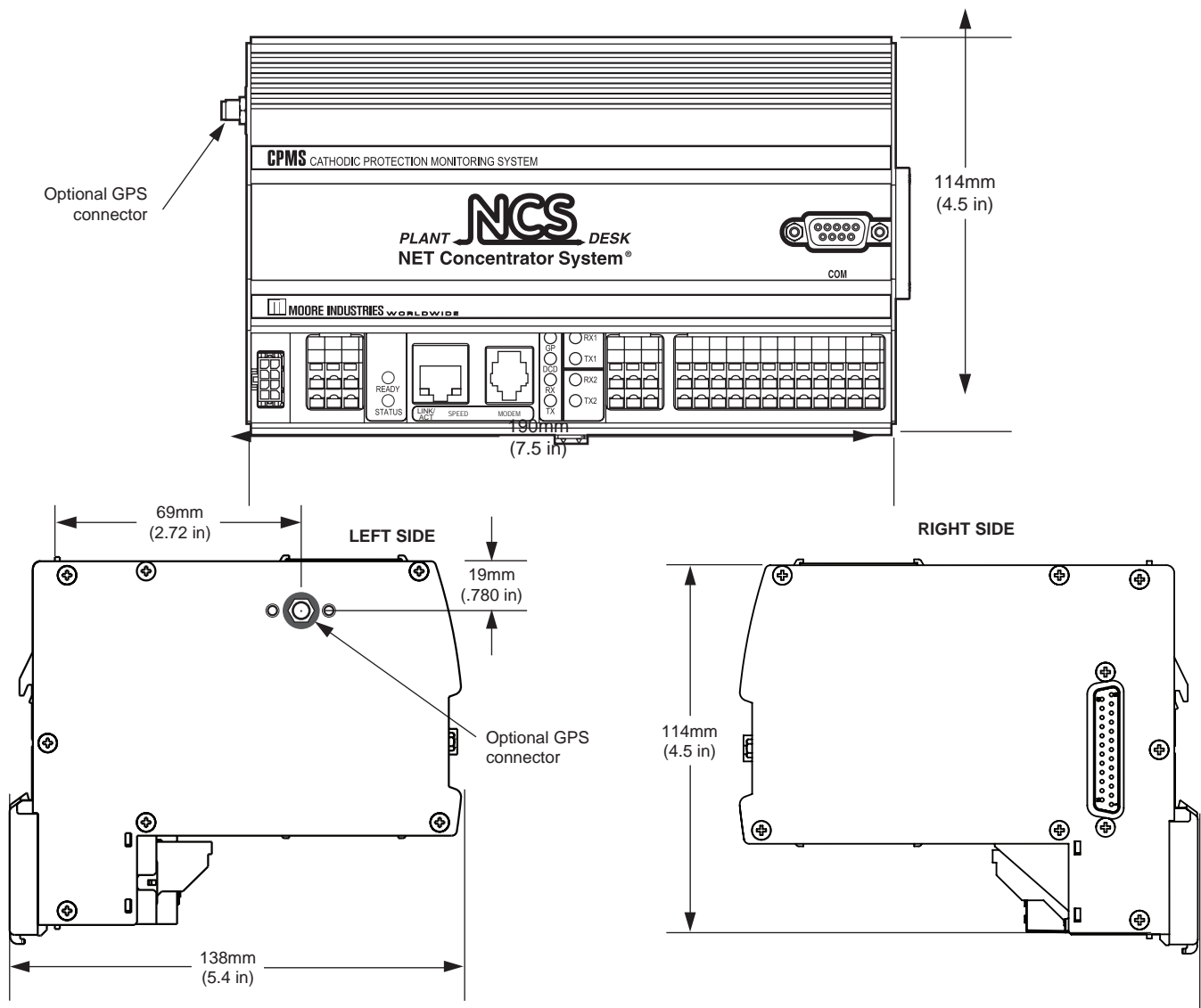

CPMS

Cathodic Protection
Monitoring System

Figure 2. CPMS Terminal Layout

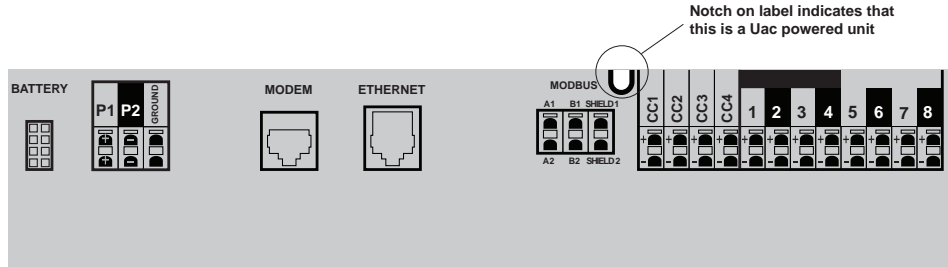

Table 3. CPMS Power, Ethernet, Modem and Contact Closure Connection Designations

Input Type	Terminal	Description
Battery	Battery	Currently unused
Power	P1	Positive Input (Applies to AC and DC inputs. Verify your unit's power requirement before applying power)
	P2	Negative Input (Applies to AC and DC inputs. Verify your unit's power requirement before applying power)
	Ground	Ground Terminal
Modem	N/A	Modem Input
Ethernet	N/A	Ethernet RJ-45 Input Connection
MODBUS	A1 B1 Shield 1	MODBUS Port 1
	A2 B2 Shield 2	MODBUS Port 2
Contact Closure	CC1	Monitors the Status of the AC Circuit Breaker of Transformer Rectifier #1
	CC2	Monitors the Status of the AC Circuit Breaker of Transformer Rectifier #2
	CC3	User-Assigned for Specific Application
	CC4	User-Assigned for Specific Application

Table 4. CPMS Terminal Designations for On-Board Input Modules

Cathodic Input Module	Channels (Refer to Figure 2)							
	1	2	3	4	5	6	7	8
1 Module	0-100V	0-100mV	-5 to +5V	4-20mA	Not Used	Not Used	Not Used	Not Used
2 Modules	0-100V	0-100mV	-5 to +5V	4-20mA	0-100V	0-100mV	-5 to +5V	4-20mA
Voltage Input Module	1	2	3	4	5	6	7	8
1 Module	0-100V	0-100mV	0-100mV	0-100mV	Not Used	Not Used	Not Used	Not Used
2 Modules	0-100V	0-100mV	0-100mV	0-100mV	0-100V	0-100mV	0-100mV	0-100mV

NOTES:

1. Terminal blocks can accommodate 14-22 AWG solid wiring.
2. Your input power requirement (AC or DC) will depend upon your unit's configuration.

CPMS

Cathodic Protection
Monitoring System

Table 5. Channel Assignments of On-Board Input Modules

Current Input Module			
Number of Modules	Channel Number	Input Type	Description
1	1-4	4-20mA	User-Assigned for Specific Application
2	1-8	4-20mA	User-Assigned for Specific Application
Cathodic Input Module			
1	1	0-100Vdc	Rectifier DC Output Voltage
	2	0-100mV	Rectifier DC Output Current (measured in mV across a shunt resistor)
	3	-5 to +5V	Structure Potential
	4	4-20mA	Spare
2	5	0-100Vdc	Rectifier DC Output Voltage
	6	0-100mV	Rectifier DC Output Current (measured in mV across a shunt resistor)
	7	-5 to +5V	Structure Potential
	8	4-20mA	Spare
Voltage Input Module			
1	1	0-100Vdc	Rectifier DC Output Voltage
	2	0-100mV	Rectifier DC Output Current (measured in mV across a shunt resistor)
	3	0-100mV	Rectifier DC Output Current (measured in mV across a shunt resistor)
	4	0-100mV	Rectifier DC Output Current (measured in mV across a shunt resistor)
2	5	0-100Vdc	Rectifier DC Output Voltage
	6	0-100mV	Rectifier DC Output Current (measured in mV across a shunt resistor)
	7	0-100mV	Rectifier DC Output Current (measured in mV across a shunt resistor)
	8	0-100mV	Rectifier DC Output Current (measured in mV across a shunt resistor)

Figure 3. CPMS Connection Diagram

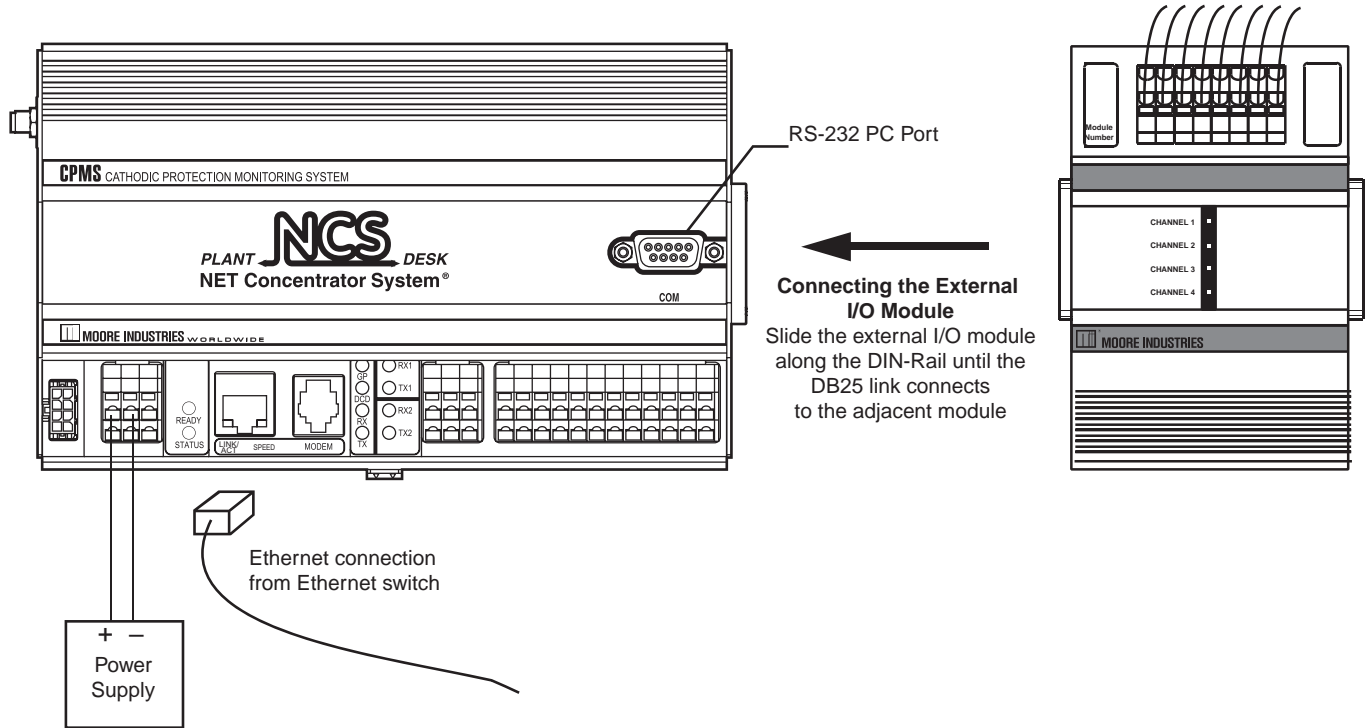

Caution:

Verify unit's input power requirement (Vdc or Uac) before applying power

24Vdc OR 90-260Vac

MODBUS Hook-Ups

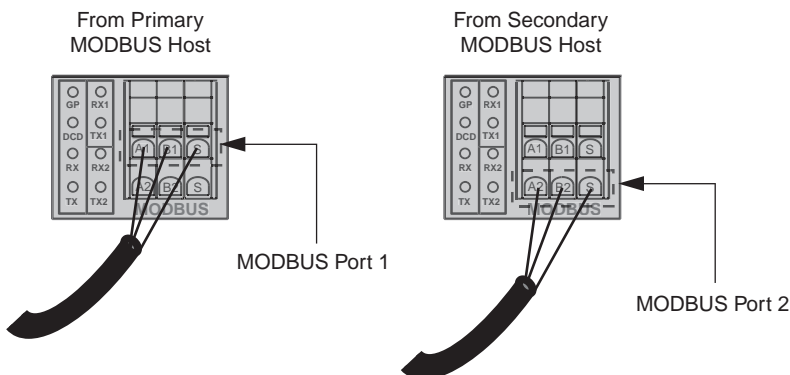

CPMS

Cathodic Protection
Monitoring System

Connecting the CPMS to the Network

Connect a power source (DC or AC depending upon your unit's configuration), an Ethernet cable connected to your network, a RS-485 connection, any required I/O modules and an RS-232 cable to your PC COM port for instrument configuration via PC. Refer to Table 6 for equipment requirements.

Refer to Tables 3 and 4 for a description of available CPMS inputs.

To install a power supply, insert a small flathead screwdriver into the pry slot, open wire terminal and place power supply wiring.

Ethernet Connection

The CPMS may be configured via web pages and FTP over the Ethernet process network or by establishing a PPP protocol through your PC's RS-232 port.

If using Ethernet, install the CPMS onto your Ethernet process network using a CAT 5 cable with an RJ-45 connector to connect the CPMS to an Ethernet switch or hub.

Note:

In Ethernet applications, hubs allow all network traffic through. This can overwhelm connected process instruments on a heavily utilized network. Switches allow only broadcasts and traffic directed to attached devices. It is recommended that switches be used in process networks instead of hubs.

For CPMS configuration using PPP protocol, connect the CPMS's RS-232 port, via DB9 connector, to an available COM port on your PC using a null modem cable.

MODBUS Connection

MODBUS RTU cabling should be shielded twisted pair. The conductors connect to the A and B terminals at one of the MODBUS ports; the shield connects to the S terminal. The second port can be connected to a second network.

Table 6. Necessary Equipment Table

Device	Description
Ethernet Network Connection	10/100 Base-T UTP
MODBUS RTU Network Connection	One or two shielded, twisted pair RS-485 connections
Power Supply	Units configured for DC input: 20-30Vdc Units configured for AC input: 90-260Vac
Personal Computer	Microsoft Windows based PC; 16Mb free RAM; 20MB free disk space on hard drive; Ethernet Port; Microsoft Windows 7 or 10 Internet Explorer (or other web browser)

GPS Antenna Connection

The CPMS offers an optional GPS Time feature. When SNTP network is not available, the -GPST option is an alternative method for accurate time keeping. This option includes an external GPS antenna which must be screwed in to the GPS port. Please refer to Figure 1.

To access real-time data, refer to the *MODBUS TCP Support* and/or the *MODBUS RTU Support* sections of this manual.

Configuring Ethernet Settings

CPMS configuration is performed using web pages and FTP, through a network interface provided by either Ethernet or PPP. To properly setup your CPMS, refer to the appropriate section of this manual—*Ethernet Connection* (if your unit is configured for Ethernet functionality) or *Establishing a PPP Connection*—depending upon the method you choose to use.

Ethernet Configuration

To configure the CPMS using Ethernet, follow the instructions below.

You must configure your CPMS for your local area network (LAN). Our Network Address Configuration (NAC) Client software will help you configure the CPMS properly. Begin by installing the NAC Client software onto your PC.

Installing the NAC Client

To install the software, insert the NAC Client CD into the CD drive of a Windows® equipped PC. Open the CD and run the *Moore NAC* program, then use the setup program to install the NAC Client. The setup program may require you to upgrade certain Windows® components before it will install.

Fixed Network Settings or DHCP

To use the CPMS on a given Ethernet network, three settings must be configured—IP address, gateway and subnet mask. The CPMS comes with DHCP (dynamic host configuration protocol) enabled, allowing the network settings to be acquired automatically when the CPMS is connected to a network with a DHCP server. If connected to a network without a DHCP server, fixed network settings must be configured in the CPMS.

Note:

If the CPMS is using DHCP at start up, the network address information displayed in the list box is how the server is currently configured. When you double-click to open the Edit window, the network settings boxes are disabled. You cannot set the IP address, subnet mask or gateway address manually if DHCP is enabled.

Caution:

The use of DHCP introduces the possibility of change or loss of IP address, caused by DHCP server outages or configuration particulars, or by an untimely power outage to the CPMS (i.e. coincident with DHCP lease expiration). Use of fixed network settings in the CPMS is recommended, and avoids these potential problems.

To access the network settings of a CPMS, run the NAC client on a PC connected to the same network as the CPMS or, if no network is available, connect a cable between the Ethernet ports of the CPMS and PC. For CPMS with firmware version 5.0 or greater, a straight or crossover cable can be used. For earlier models a crossover cable is required for direct connection to the PC or a straight cable can be used via a LAN switch.

Start the NAC client by clicking on the icon in the *Start Menu*. Once the program is running, click *Find All*.

If more than one CPMS is on the network, the NAC Client will list them all. Disconnect the network cable from the CPMS in question, click *Find All* again and determine which CPMS disappeared from the list.

To change the network settings for a station, double-click on the station that you want to change. This will open a second window where you can view and change all network settings. Click *OK* when you are finished.

The station will change the settings and respond with a message indicating that the system will reboot in 10 seconds. If you receive an error, you may have an incorrect setting in the network window. Note that the new settings do not appear in the NAC utility list window. To view the new network settings, click *Find All* in the NAC utility after the system is rebooted.

Verifying the CPMS Station Ethernet Connection

To test the station's Ethernet connection, open Internet Explorer and type the IP address of the station into the URL bar.

If security is in *Closed* mode, this will bring up the *Log In* page. You will need to supply an account name and password to access the web pages. An administrator-level account will be required to change network settings. If security is in *Open* mode, you will be sent directly to the home page.

Note:

The CPMS has a default security setup of Open; no password is required to access any and all levels of the software.

You can also connect to the station using an FTP client tool. Simply open an FTP connection to the station using its IP address as the site address. The same username and passwords apply as for the web server. However, the default *Guest* account does not have FTP access so only the *root* account (default password of *password*) can successfully connect using FTP.

CPMS

Cathodic Protection
Monitoring System

CPMS Web Server

The CPMS contains its own configuration program in the form of an embedded web server. Pages can be accessed using Internet Explorer. For directions, refer to *Connecting the CPMS*. The Web Server is comprised of the sections below:

- 1. Home Page**—This page is the NCS Interface Module Home Page. On it, you will find all the options you will need to configure your system. For quick reference, fault messages are listed on the home page.
- 2. Process Status**—This screen continuously monitors and displays the activity of a selected I/O module, updating its display as frequently as every five seconds (update rate is user-configurable).
- 3. I/O Modules**—This web page allows you to change the settings of the different modules attached to the CPMS. For example, this screen will permit you to change the measurement type, input range and other measurement parameters of the internal modules and any other externally attached I/O module. Select the appropriate module and channel, adjust the parameters, then press *Commit* to transfer the configuration to the Interface Module.
- 4. Interface Module**—The *Interface Module* page includes a number of selections that provide all the necessary options for setting the system parameters of the Interface Module.
 - a. System Information**—Lists the CPMS server information and displays the amount of storage space left in the CPMS.
 - b. System Time**—Allows you to set the CPMS to the workstation time, to set it manually, or to retrieve the time from a network time server. Units ordered with the GPS option can also be configured to synchronize the time with GPS.
 - c. Modbus**—Allows you to set the Floating Point Word Order, configure MODBUS RTU ports, reset MODBUS Master Scheduler, display pop-up window for MODBUS master transfer status and indicates any MODBUS errors. If the floating point data displayed on your MODBUS Master appears incorrect, switch the floating point word order.

- d. Web Data Display**—Allows you to adjust the rate at which the web server updates information and the precision (decimal place) it uses when displaying information.

- e. ISaGRAF**—You may start and stop ISaGRAF control, view status and errors and clear retain variables.
- f. Contact Closure Tags**—From here you can assign individual tags, or identifying descriptions, to your contact closure relays.

- 5. Data Logger**—The *Data Logger* screen allows you to manipulate the data log of the Interface Module. The Data Log records information at a selected interval from specified input channels. From the *Data Logger* page, you can navigate to web pages where you can configure the data logger, view the data logger status or retrieve the data log.

- a. Configure Data Logger**—This page allows you to configure which modules and channels are being logged, the frequency of the logging and log file size and action on power recovery. When the desired settings have been made, start the logger by pressing *Update*, then *Start*.

You can also retrieve and download the data log from the *Configure Data Logger Page*. To retrieve the logged data, first click *Stop* to stop logging data. As long as there is logged data and the logger is stopped, you will see a link for *Save Data Log Locally*. Click this link and follow the steps displayed in the *File Download* pop-up window.

- b. View Logger Status**—Lists the health and specifications (current number of records and status message) of the data logger.
- c. View Data Log**—Lists the current log and each recorded value.

- 6. Security**—The *Security* page includes a number of selections that provide all the necessary options for setting the security of the Interface Module. For more information on how to setup user accounts and change access privileges, refer to the *CPMS Security* section of this manual.

- a. Change Password**—The screen where users change their logon password.

- b. **Security Mode**—Changes the security from *Open*, where passwords are unnecessary, to *Closed*, where passwords are enforced.
 - c. **User Accounts**—Enables you to set the ability of each user to access various pages of the CPMS program, modify passwords, and read or write using a FTP program.
7. **Logout**—Logging Out ends your session.
 8. **Help**—Connects you to the help system.

Figure 4. CPMS Home Page

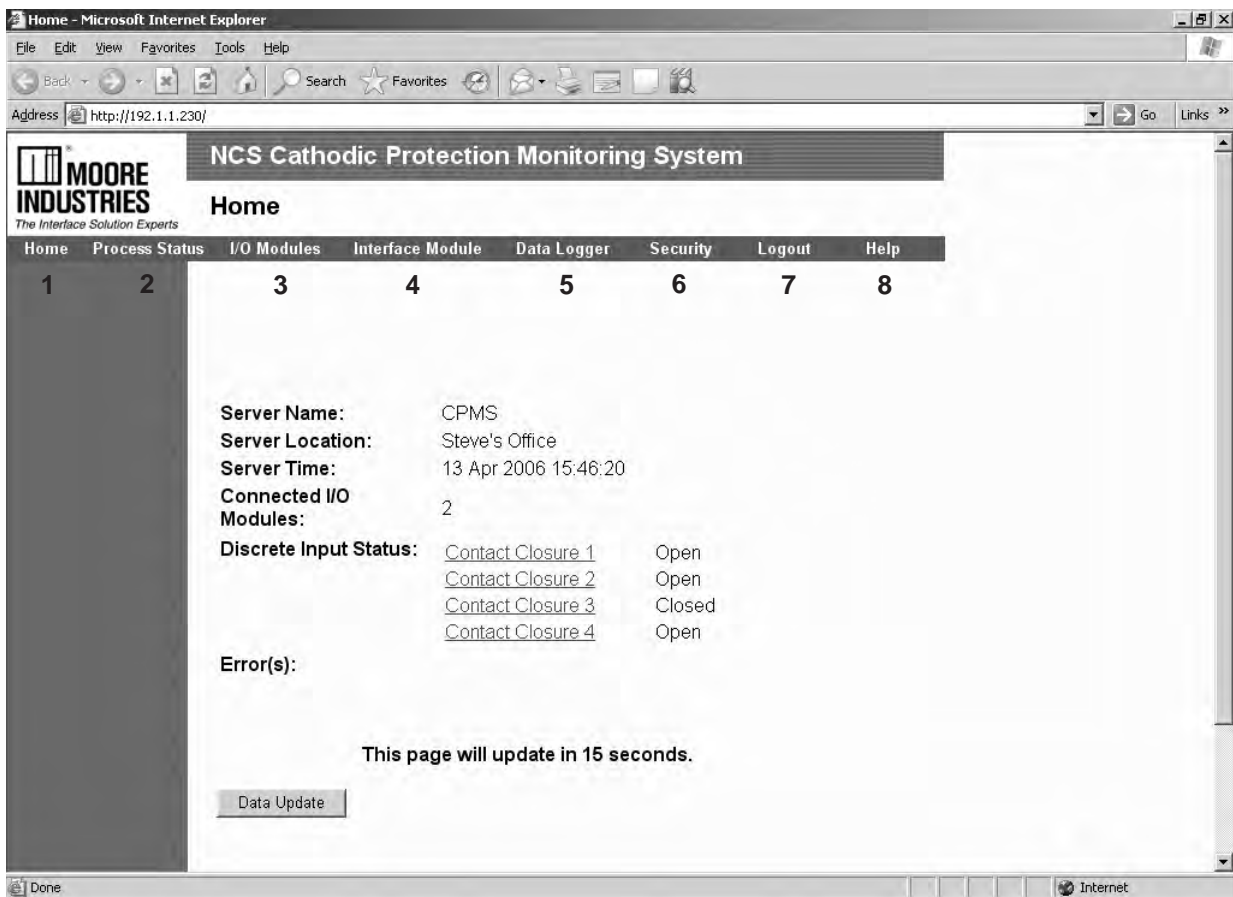

MODBUS Configuration

To configure MODBUS parameters, first navigate to the *Modbus* section in the *Interface Module* dropdown menu.

The following parameters must be configured for each MODBUS port that will be used.

1. **a. Floating Point Word Order**—Use this field to select *Standard LSW* or *Swapped MSW*. By default, the CPMS will use the *Standard LSW* first (least significant word) floating point word order format. This stores the most significant bits in the second register and the least significant bits in the first register. Selecting *Swapped MSW* (*most significant word*) will reverse the order, storing the most significant bits in the first register and the least significant bits in the second register.
- b. Mode**—Use this field to configure your unit as a MODBUS Master or Slave or choose to disable MODBUS functionality.
- c. Address**—A MODBUS Address is the number that the CPMS uses to identify itself on the MODBUS network. Select a value between 1 and 247 (default is 1). If both MODBUS ports will be used on the same MODBUS network, they **must** have different addresses. They may have the same address if they are on independent MODBUS networks.
- d. Baud**—Baud rate is the speed of data transmission. It should be set to match the value of the attached controller for slave. Factory default is 9600.
- e. Parity**—A method in serial asynchronous communications of “checking” that characters have been sent correctly to help reduce errors. This should be set to match the properties of the bus. Even, Odd and None (no parity) are supported. Factory default is None.
- f. Character T/O**—This relaxes timing when receiving MODBUS messages. It allows for silence in between communication without declaring a fault. This is a user-selectable value represented in character times. Factory setting is *Default*.

g. Response Delay—This causes the CPMS to pause before transmitting a generated MODBUS response. This is a user-selectable value represented in character times. Factory setting is *Default*.

h. Response T/O—This function is available when the CPMS is in MODBUS Master mode. This is the time that a MODBUS master will wait for a response, before declaring a fault, after issuing a command to a slave. The units are represented in mS.

When you have completed configuration of MODBUS parameters, click *Update Settings*.

Note:

Clicking Reset Schedule will delete all scheduled MODBUS Master transfers, clear all MODBUS Master errors and reload the schedule.ini file.

To view MODBUS Master status for scheduled transfers, click the *Status Details* button.

Figure 5. MODBUS Configuration Web Page

The screenshot shows a web interface for MODBUS configuration. At the top, there is an 'Error(s):' field with the value 'None'. Below it is a 'Floating Point Word Order:' dropdown menu set to 'Standard (LSW first)'. The main configuration area is divided into two columns for 'Modbus 1' and 'Modbus 2'. Each column contains the following settings: 'Mode' (Slave), 'Address' (1 for Modbus 1, 2 for Modbus 2), 'Baud' (9600), 'Parity' (None), 'Character T/O' (Default), 'Response Delay' (Default), and 'Response T/O' (100). At the bottom of the form are three buttons: 'Update Settings', 'Reset Schedule', and 'Status Details'.

Configuring the CPMS as MODBUS Master

To use the CPMS as MODBUS master, follow the instructions below.

Note:

The MODBUS Master capability described in the following section does not apply to MODBUS TCP. It only applies to MODBUS RTU.

Caution:

Ensure that the safe mode jumper is in the Normal/Enabled mode (refer to CPMS Security section). MODBUS master capability will not initialize if the jumper is placed in reset mode.

Access the MODBUS RTU port. In the configuration interface, the MODBUS RTU port must be placed into master mode and the port must be configured with the device address, baud rate, parity, character timeout and response delay for the intended network. You must also set the master timeout parameter.

To begin, create a *schedule.ini* file (scheduler file). This file is used in order to specify all MODBUS master queries. Along with queries, you may enter comments. These begin with the “#” symbol and may be used as notes, tags, messages, etc. for the person writing to and viewing the schedule.ini file. The schedule.ini file will be placed into the CPMS via FTP once complete.

A scheduler entry corresponds to a single MODBUS query. The format of a single entry consists of a comma separated list of eight required fields (there are also two optional fields). These fields include:

Name– A user-selected string that is used to identify the transfer. The MODBUS master status webpage will list the transfers using this name.

Port– This represents the MODBUS port on the CPMS. This is an integer value corresponding to a single physical MODBUS port (the number “1” representing MODBUS Port 1; “2” representing MODBUS Port 2).

Interval– The interval in milliseconds (msec) at which the query should be sent.

Slave Address– The address of the slave device to which the query should be sent.

Function– Represents function codes which are supported by the CPMS (shown below).

Code	Description
1	Read Coil Status
2	Read Input Status
3	Read Holding Registers
4	Read Input Registers
5	Force Single Coil
6	Preset Single Register
15	Force Multiple Coils
16	Preset Multiple Registers

Slave Start– The coil/register on the slave device to be read/written by the query. For queries that involve a range of coils/registers this value corresponds to the first coil/register in that range. This value is the source coil/register for reads and the destination coil/register for writes.

Count– The number of coils/registers to be read or written by the query.

Note:

For Function codes 5 and 6 the Count value must be 1. Values other than this generate an invalid definition error.

CPMS

Cathodic Protection Monitoring System

Master Start– The coil/register on the MODBUS master to be used as a source for writes and a destination for reads. For queries that involve a range of coils/registers this value corresponds to the first coil/register in that range.

Fail Coil– The coil in the CPMS's register map where errors with the transfer are reported.

Following the execution of a transfer, a value of 1 written to the fail coil indicates that an error has occurred with the transfer. Refer to ***Note**.

It is possible for multiple transfers to use the same fail coil. In this case, any error in those transfers (logical OR) will set the coil to true.

Enable Coil– The coil in the CPMS's register map that is used to control whether or not a transfer should be executed. A value of zero in this field means no enable coil is used (i.e. execution of the transfer can not be inhibited). Refer to ***Note**.

It is possible to have multiple transfers use the same coil, thereby allowing a group of transfers to be controlled by a single coil.

***Note:**

It is possible to leave the Fail and/or Enable Coil fields off if the coils are not going to be used. However, it is recommended that a value of zero be used to explicitly indicate this.

Refer to Figure 6 for two examples of complete scheduler entries.

Figure 6. Example of Scheduler Entries

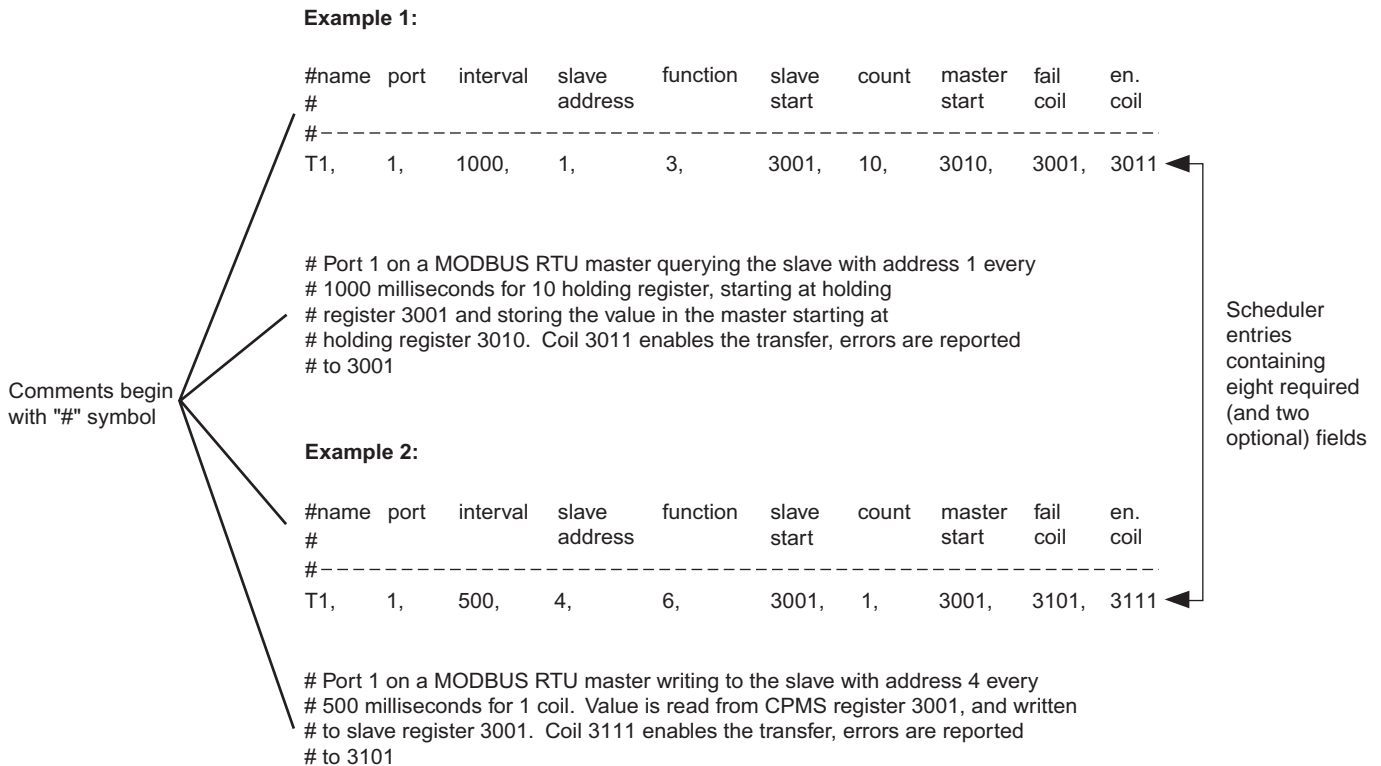

Configuring the Data Logger

The Data Logger records process variable data at a selected interval from specified I/O channels. From the Data Logger menu item you can access web pages where you can configure the data logger, view status or data log records.

Using Moore Industries' EIM capabilities, the CPMS is capable of storing 64,000 points of time-stamped data. Upon power loss, non-volatile memory retains the most recently stored 18,000 data log records. A station can be configured to store data from one, or all, of its input channels. Sampling rate is user-selectable for any period between 100msec to once every 24 hours. Follow the directions below to complete the data logger configuration.

Upon power loss, or if the logger is intentionally stopped, new data is appended to the previously saved data.

Note:

Before configuring the data logger, ensure that you log on with the appropriate security rights. For information on security rights, see the CPMS Security Overview section of this user's manual.

1. From the Home Page of the CPMS, select the *Configure Data Logger* option located in the *Data Logger* dropdown menu.
2. In the *Channel Selection* area, choose the channels that you want to log. If you want to log more than one channel, hold the *Control* key down while selecting the multiple channels. Alternatively, you can use the *Shift* key to select a group of contiguous channels.
3. Next, specify the *Sample Period* at which you want to log the selected channels.
4. In the *Maximum Records Per Channel* area, enter the number of records per channel you would like to log. If you are logging two channels and you entered a value of 25, your data log file will contain a total of 50 records. If the number you enter exceeds the maximum number of records, the maximum number will be adjusted when you click *Update*.

Figure 7. Data Logger Configuration Web Page

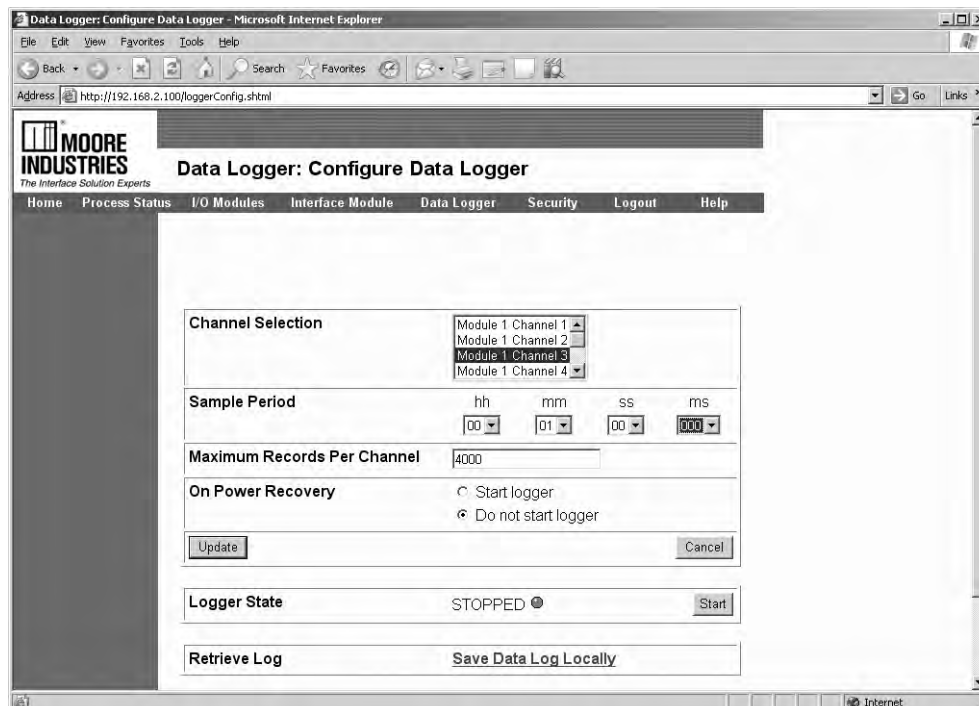

CPMS

Cathodic Protection Monitoring System

5. Now select how you would like the data logger to react if power is lost to the CPMS while the data logger is running. By selecting *Start the Logger*, the data logger will be restarted upon power up. However, this only applies if the data logger was running when power was lost.

These settings do not apply if the logger was off prior to power loss.

6. After reviewing your configuration, click the *Update* button to download the setup details of the CPMS.

Note:

Clicking the Update button clears the log, whether or not changes have been made.

7. Finally, click the *Start* button to start the data logger.

You can now view the recorded data on the *View Logger Status* option from the *Data Logger* menu. When the *Maximum Records Per Channel* value has been reached the data logger will stop running. You can now download the data log .csv file.

Refer to the *CPMS Web Server* section (Step 5) of this manual for information regarding downloading of logged data.

Note:

Data cannot be downloaded while the data logger is running.

Accessing a Data Logger File

The data logger saves data in text format. To access this file, follow the instructions below.

Note:

Before attempting to retrieve the data log as a file, ensure that you logon with the appropriate security rights. Refer to the CPMS Security section of this manual for more information.

1. Select the *Configure Data Logger* option from the *Data Logger* menu.
2. If the data logger is running, stop it by clicking the *Stop* button.

Note:

The data logger must be stopped in order to retrieve the data log as a file.

3. Click the *Save Data Log Locally* hyperlink.
4. At the *File Download* box, select whether to *Open* or *Save* the file to another location.
5. The spreadsheet opens as a .csv file in Microsoft Excel®, you are able to make any modifications or changes that you require.

If you select to *Open* the spreadsheet directly from the webpage and make any changes to data, you will need to perform a *Save As* function in order to save the information. Therefore, you will need to assign a file name and location for the modified spreadsheet on your local PC or network.

If you choose to *Save* the file when opening, you may make whatever changes are needed and save them directly to the file in its present location.

No changes that you make will be saved directly to the CPMS's data logger.

6. Saving the spreadsheet to a different location brings you back to the webpage once downloading has completed.

If you selected to *Open* the file, you may use the *Go To* drop down menu to navigate back to the desired page.

CPMS Security

The Security page of the NCS web server allows an administrator to determine which users are allowed access to which portions of the NCS configuration software. There are three different user types; each user type has different security restrictions.

Administrator

The administrator is allowed read and write access to all pages.

Power User

The power user can read and write all pages except the security pages. (Although he is allowed to change his own password on the security page.)

Guest

A guest has no write privileges, but can read any pages except the security pages. The guest also cannot access or update saved configuration files or change his or her password.

Changing the Security Settings

To add or edit user accounts, the Interface Module must be in closed security mode and you must log in with an administrative password. The default security mode is open, so first click on *Security*, then *Security Mode* and set it to closed. Finally, log out.

Log on using an administrative account. The default administrator account is *root* with a password of *password*. When the NCS Home Page is displayed, click on *Security*, then any of the options you wish to change. Log out when you are finished.

Resetting Interface Module Passwords

The password function is a valuable security tool, but can be troublesome when the password is lost, forgotten, or erroneously set. If you cannot access the Interface Module's web server because of a missing password, there are two options.

First, try to log on using the default administrator username of *root* with the password of *password*. This may have already been replaced by your current administrator password. If that is the case, you will need to reset the passwords using the following steps.

Note:

All previously setup user accounts will be deleted when you reset the password jumper.

1. Power down the Interface Module by removing the power cables from it.
2. Remove the left side panel from the Interface Module by removing the six side panel screws.
3. Place the safe mode jumper on both pins as illustrated in Figure 8 under the *Passwords Reset/Disabled* illustration, and power up the Interface Module.
4. Power down the Interface Module and remove the safe mode jumper, placing it back on the jumper as shown in the *Passwords Normal/Enabled* illustration. Replace the side panel, and power up the module. It is now ready for use.
5. Start the Web Server, and use the administrative account with a username of *root* and a password of *password*, to access the system and make any necessary changes. A guest account with the username of *guest* and a password of *password* is also available for use.

Figure 8. Safe Mode Jumper Location

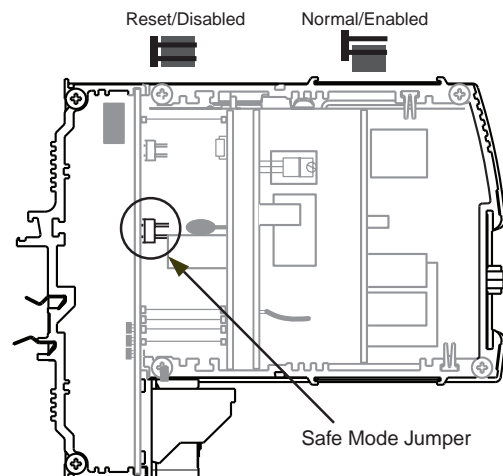

CPMS

Cathodic Protection
Monitoring System

User Accounts

To add, update or create user accounts you must access the *Security* section of the CPMS web page. Ensure that security is in *Closed* mode; you cannot make changes to user accounts in *Open* mode.

Adding an Account

To add a new account, click the *Add Account* button. At the next screen you will be asked to enter the User Name, Password and then to verify the selected password.

Next, select the *Permissions* level of the user—Administrator, Power User or Guest. When all information is correct, click *Add*.

Updating an Account

Click the button to the left of the account you wish to update. Click the *Update Account* button. Select the *User Level* which you want to apply to the account. Click *Update*.

Deleting an Account

To delete an existing account, click the button to the left of the account; click *Delete Account*. For verification, at the next page you will be asked whether to *Cancel* or *Delete* the account. Click the appropriate button.

Hot-Swapping an I/O Module

Should an external Input/Output Module need to be replaced, you do not need to power down the Cathodic Protection Monitoring System. Instead, simply remove the old module from the terminal base, and snap in the new one.

Programming a New Module

The CPMS uses the configuration present in the new module. If the new module has the same configuration as the one being replaced, nothing else needs to be done. If not, the new module must be programmed using the directions in the configuration section.

Removing the Old Module

Begin by taking two small flathead screwdrivers and inserting each under a different base clip, as shown in Figure 9. With the base clips pulled away, pull the module out from the base.

Snapping in the New Module

Check to see that the keying post (shown in Figure 10) will line up properly with the keying hole in the bottom of the module. If it does not, rotate the module 180°. If it still does not line up, the module is of the wrong input type. The new module must be of the same type as the previous module.

Slip the new module into the base from which the old one was removed. Push it firmly into position. The lights on the face of the input/output module should glow as the unit powers up. Your new I/O module is now in service.

Note:

A new I/O module will only work with an identical type of base. The new module must replace an identical older module.

Figure 10. Snapping in a New Module

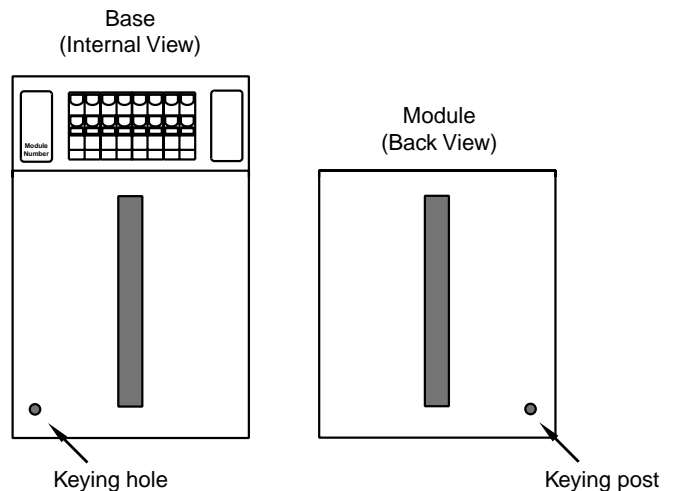
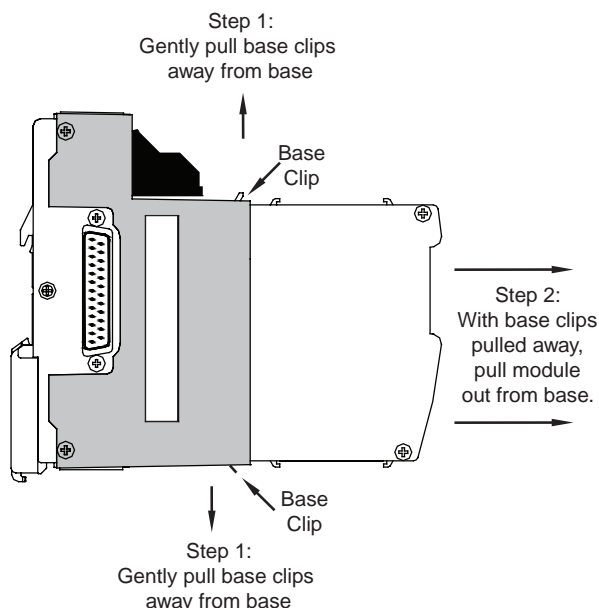

Figure 9. Removing the Old Module



CPMS

Cathodic Protection
Monitoring System

On-Board Input Module Configuration

The Input Module contains four input channels of different configurations. Configuration Web pages for Voltage Channels are the same, except for the specific input ranges of the channel being configured. Current channels differ in configuration with the addition of Custom Curve and Trimming capability.

To configure the CPMS's on-board Input Modules (Current, Voltage or Cathodic) follow the steps below.

Channel Selection

Select the channel you wish to program (1-4).

Channel Disabled

Checking this box will cause the module and the associated CPMS to ignore the selected channel, allowing you to use less than all four channels without receiving error messages.

Tag Name

Allows you to place an identifying descriptor (24 alphanumeric characters, maximum) to the Module being configured.

Note:

Space is an illegal character and will cause errors. Use an underscore (_) instead of using a space.

Input Type

This sets the type of input that the Input Module will receive. Different measurement types require different parameters to be programmed. When a measurement type is selected, other parameters may become red, indicating that the red parameter must be programmed.

Input Ranging

Allows you to either input or capture the upper and lower ranges that you want to have measured.

Filter

This setting is used to configure the input filter. This filter is designed to reduce the effects of mains-induced noise. The value should be set to the frequency of the local AC supply—either 50Hz or 60Hz.

File Management

If you will be using a common configuration within your system, you can create a configuration and save it to a file so that you can load it into another I/O module. Refer to the *File Management* section of this manual for more information.

Input On Failure

From here you may select how your input value reacts upon a failure. Selecting *Hold Last* maintains the value last read before the failure. To display a user-selected value, click the *Preset* button and then enter the value into the *Predefined Value* text box.

Input Scaling

Input Scaling allows you to take the input and convert it to a different range with custom engineering units. For example, if you take a channel with a 0-100mV range and choose input scaling with a range of 0-10Amps; now when the input is 75.4mV, it is relayed to the Interface Module as 7.54Amps.

Custom Curve (applicable to Current input channels only)

The Custom Curve box allows you to setup a custom linearization table of up to 128 points that will tell the channel what value to output when a certain input is received. This is accomplished by loading into memory a *comma-separated value* file (.csv) that was created in Excel® or a similar program. Refer to the *Loading a Custom Curve File* section of this manual for more information.

Custom Engineering Units

The I/O configuration web pages allow you to customize the process variable engineering units (EGU). The data can then be viewed on the *Process Status* page with the correct units.

Figure 11a. Cathodic Input Module Configuration Web Page

Module 1: Cathodic Input Module

Current Channel: 1 ▾

Channel Disabled <input type="checkbox"/>	File Management <input type="button" value="Load File"/> <input type="button" value="Save File"/>
Tag Name Tag: <input type="text"/>	Input On Failure: <input type="radio"/> Hold Last <input checked="" type="radio"/> Preset Predefined Value: <input type="text" value="0.000"/>
Input Type Volts ▾	Input Scaling <input type="checkbox"/> Enabled Lower Scaled Value: <input type="text" value="0.000"/> Upper Scaled Value: <input type="text" value="100.000"/>
Input Ranging Limits: 0 to 100 V Minimum Span: 51 V Lower Range Value: <input type="text" value="0"/> Upper Range Value: <input type="text" value="100"/>	Custom Engineering Units EGU: <input type="text"/>
Filter <input type="radio"/> 50Hz <input checked="" type="radio"/> 60Hz	

Figure 11b. Voltage Input Module Configuration Web Page

I/O Modules: Configure Voltage Input Module 1

us I/O Modules Interface Module Data Logger Security Logout Help

Current Channel: 1 ▾

Channel Disabled <input type="checkbox"/>	File Management <input type="button" value="Load File"/> <input type="button" value="Save File"/>
Tag Name Tag: <input type="text"/>	Input On Failure: <input type="radio"/> Hold Last <input checked="" type="radio"/> Preset Predefined Value: <input type="text" value="0.000"/>
Input Type Volts ▾	Input Scaling <input type="checkbox"/> Enabled Lower Scaled Value: <input type="text" value="0.000"/> Upper Scaled Value: <input type="text" value="100.000"/>
Input Ranging Limits: 0 to 100 V Minimum Span: 51 V Lower Range Value: <input type="text" value="0"/> Upper Range Value: <input type="text" value="100"/>	Custom Engineering Units EGU: <input type="text"/>
Filter <input type="radio"/> 50Hz <input checked="" type="radio"/> 60Hz	

Sensor Trimming (applicable to Current input channels only)

The current channel can be trimmed with two data points within the selected zero and span measurement range. This allows a complete range to be monitored, while placing a measurement emphasis on the most critical segment of the process range.

To perform sensor trimming, follow the steps below.

1. Select the channel you wish to trim; click the *Trim / Enable* link on the associated web page.
2. Click the *Trimming enabled* checkbox. Depending on your function, select *1 point trim* or *2 point trim*.
3. To trim the lower point, enter the value that you would like displayed as your process variable (PV) into the *Lower* text box. Input that value into the channel using your input device.

4. Click the *Trim Lower* button. This will bring up a pop-up window to input the value that you entered as your lower trim point; click *Accept* if you are satisfied with the data received by the Module.

The captured value will update to this value on the *Current Input Trimming* screen.

5. If performing 2 point trimming, repeat Steps 4 and 5 for the upper trim point.
6. Click *Submit* to save the trimming values and continue to the next channel.

Repeat these steps for each channel that requires trimming.

Commit/Cancel Buttons

Click *Commit* when you are finished selecting parameters to save the settings to memory. *Cancel* ends your configuration process without saving.

Figure 12. Current Channel Configuration Web Page

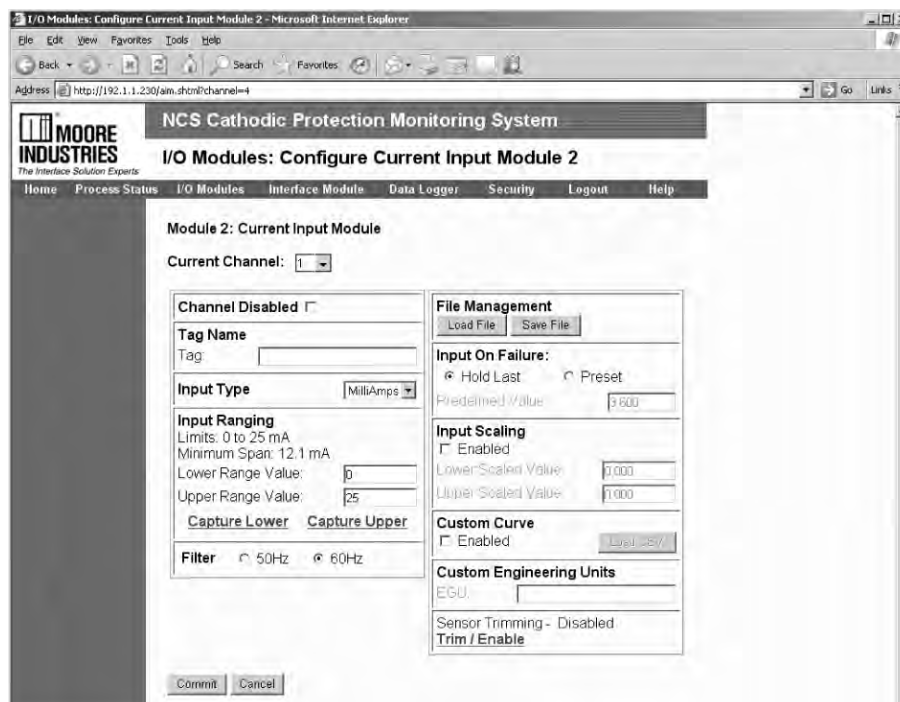

The AIM Analog Input Module

The Analog Input Module (AIM) isolates and conditions four analog signals and relays input information to the CPMS Module.

Installing the AIM

Installation consists of physically mounting the unit, completing the input connections and grounding the unit.

Mounting

The AIM is designed to snap easily onto 35mm Top Hat (EN50022) DIN- rails. Snap the AIM onto the DIN-rail to the right of the CPMS, then slide it along the rail until the DB25 connectors on the side of the AIM connect completely with the unit to its left. See Figure 15 for illustration.

Recommended Ground Wiring Practices

Moore Industries recommends the following ground wiring practices:

- Any Moore Industries product in a metal case or housing should be grounded.
- The CPMS individual module bases are mechanically grounded when installed onto the DIN-rail. Be sure the DIN-rail is connected to a system safety earth ground before making any other connections.
- All input signals to, and output signals from, Moore Industries' products should be wired using a shielded, twisted pair technique. Shields are to be connected to an earth or safety ground near the unit itself.
- The maximum length of unshielded input and output signal wiring should be 2 inches.

Input Connections

After mounting, you may connect the analog inputs to the AIM. Since the AIM receives power from the connected Interface Module, only the analog inputs need to be connected. Figure 15 shows the connection diagrams for an AIM.

CE Conformity

Installation of any Moore Industries' product that carries the CE compliance marking (Commission Electro technique) must adhere to their respective installation guidelines in order to meet the requirements set forth in applicable EMC (Electromagnetic Compatibility) directive (EN 61326). Consult the factory for additional information.

CPMS – AIM

Cathodic Protection System
Analog Input Module

Specifications

AIM Analog Input Module (4 Channels) Up to Eight Per Interface Module

<p>Performance</p> <p>Input Ranges: Programmable for any range within: Current, 0-25mA (4mA minimum span) or Voltage, -10V to +10V (1V minimum span) Accuracy: ±0.01% of maximum span Input Resolution: 20-bit Stability (% of maximum span): Current: 1-year, 0.047%; 3-year, 0.081%; 5-year, 0.11% Voltage: 1-year, 0.066%; 3-year, 0.11%; 5-year, 0.15% Isolation: 500Vrms, continuous, from channel to channel, from each channel to case, and from each channel to terminals of other attached CPMS modules; will withstand 1000Vrms dielectric strength test for one minute (with no breakdown) from each channel to case, and from each channel to terminals of other attached CPMS modules</p>	<p>Performance (continued)</p> <p>Scan Time: The time required for the CPMS Module to access process variable and status data from all four channels of the AIM is 16ms Response Time: 60ms Input Impedance: Current, 20 ohms; Voltage, 1 Mohm Maximum Input Overrange: Current, ±100mA; Voltage, ±30V Power Supply: Power is supplied by the CPMS Module, 4W maximum Input Filter: User-Programmable for 50Hz or 60Hz noise rejection Linearization Capability: Custom curve tables can be configured with up to 128 points using Internet Explorer web pages or PC-based software Transmitter Excitation: 21V/24mA excitation for powering a 2-wire transmitter Diagnostic Information: Refer to Table 14</p>	<p>Status and Fault Indicators One red/green LED per channel indicates proper channel operation (green) or that the channel is in a fault condition (red)</p> <p>Ambient Conditions Operating Range: -40°C to +85°C (-40°F to +185°F) Storage Range: -40°C to +85°C (-40°F to +185°F) Ambient Temperature Effect: 0.01% of maximum span/°C Relative Humidity: 0-95%, non-condensing RFI/EMI Protection: 20V/m @20-1000MHz, 1kHz AM when tested according to ENC61000-4-3-1996 Common Mode Rejection: 100dB@50/60Hz Normal Mode Rejection: Current, 60dB typical@10mA_{p-p}; Voltage, 60dB typical@1V_{p-p}, 50/60Hz</p> <p>Weight 562 g (19.8 oz)</p>
--	---	---

Specifications and information subject to change without notice.

Figure 14. AIM Dimensions

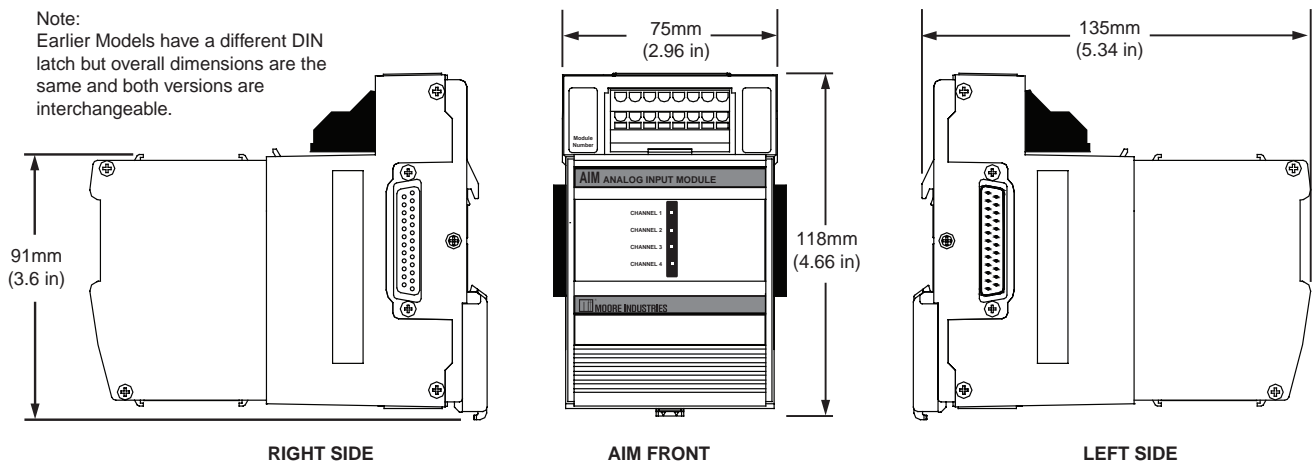

CPMS – AIM

Cathodic Protection System
Analog Input Module

Figure 15. AIM Connection Diagram

Refer to Figure 31 for Terminal Designations

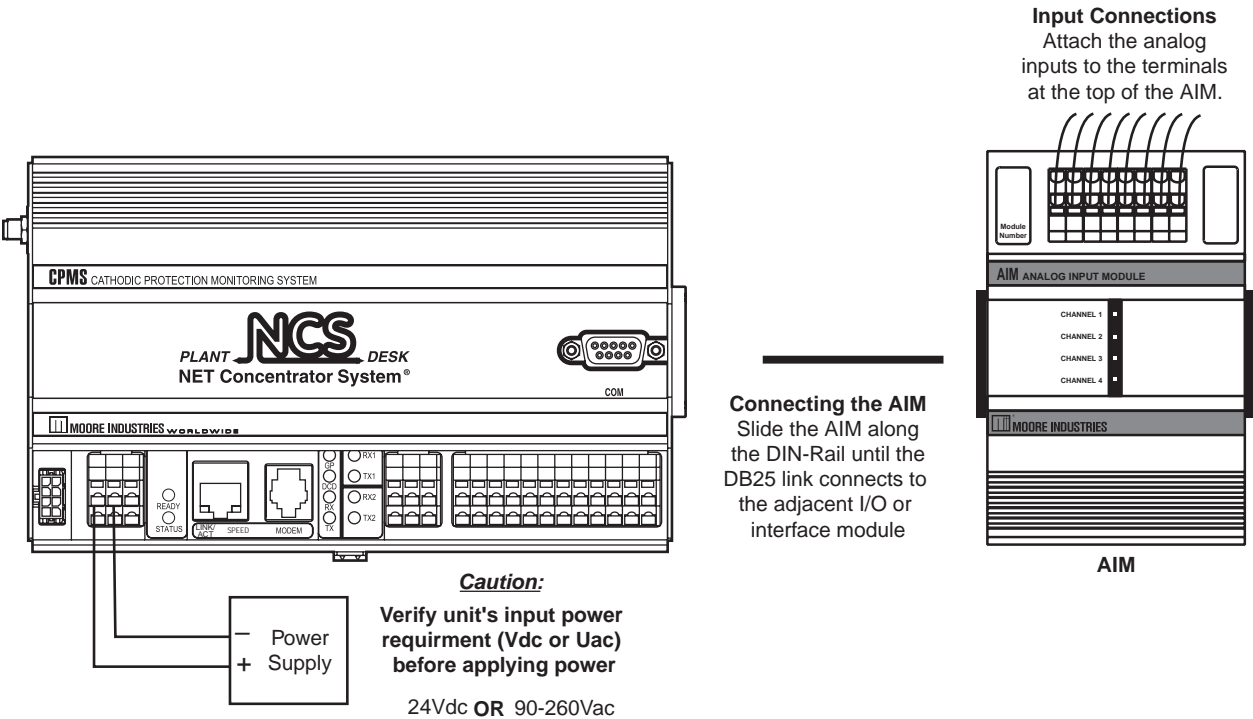

Terminal Connections

Current input with Transmitter Excitation

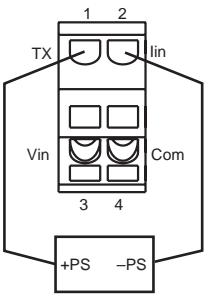

Current input without Transmitter Excitation

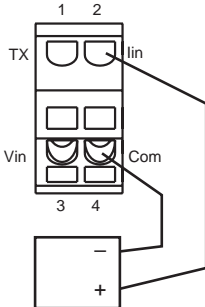

Voltage Input

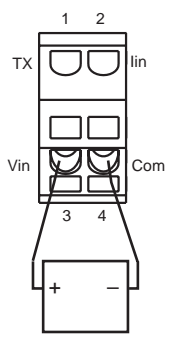

NOTE: To install wires into the terminals, insert a small, flathead screwdriver into the pry slot, open wire terminal and place wire.

CPMS – AIM

Cathodic Protection System
Analog Input Module

Configuring the AIM

The AIM is configured using the web server contained within the Interface Module to which it is attached. To configure the AIM, you must first mount it to the Interface Module as described in *Installing the AIM*. To access real-time data using MODBUS commands instead of the web server, see the *MODBUS/TCP Support* section of this manual.

After mounting, bring up the CPMS configuration software by starting an Internet browser on a computer attached to the same network as the CPMS, and typing *http://* followed by the IP address that the Moore Industries NAC Client software lists for your Interface Module.

Once you have accessed the CPMS configuration software, click on *I/O Module*, then *Configure Analog Input Module*. Configure the parameters listed on the screen, and when you are finished, select *Commit*.

Current Channel

The AIM accepts four different analog inputs, and uses a separate channel for each. Select the channel you wish to program.

Channel Disabled

Checking this box will cause the AIM and the associated CPMS to ignore the selected channel, allowing you to use less than all four channels without receiving error messages.

Tag Name

Allows you to place an identifying descriptor (24 alphanumeric characters, maximum) to the AIM being configured.

Note:

Space is an illegal character and will cause errors. Use an underscore (_) instead of using a space.

Input Type

This sets the type of input that the AIM will receive. Different measurement types require different parameters to be programmed. When a measurement type is selected, other parameters may become red, indicating that the red parameter must be programmed.

Input Ranging

Allows you to either input or capture the upper and lower ranges that you want to have measured.

Filter

This setting is used to configure the input filter. This filter is designed to reduce the effects of mains-induced noise. The value should be set to the frequency of the local AC supply—either 50Hz or 60Hz.

File Management

If you will be using a common configuration within your system, you can create a configuration and save it to a file so that you can load it into another I/O module. Refer to the *File Management* section of this manual for more information.

Input On Failure

From here you may select how your input value reacts upon a failure. Selecting *Hold Last* maintains the value last read before the failure. To display a user-selected value, click the *Preset* button and then enter the value into the *Predefined Value* text box. The unit displayed will depend upon the *Input Type* that you have chosen (MilliAmps or Volts).

Note:

Voltage is not a valid selection for the analog inputs mounted on-board the CPMS.

Input Scaling

Input Scaling allows you to take the input and convert it to a different range. For example, you take a channel with a 0-10V range and scale it to 0-100V; now when the input is 7.34V, it is relayed to the Interface Module as 73.4V.

Custom Curve

The Custom Curve box allows you to setup a custom linearization table of up to 128 points that will tell the AIM what value to output when a certain input is received. This is accomplished by loading into memory a *comma-separated value* file (.csv) that was created in Excel® or a similar program. Refer to the *Loading a Custom Curve File* section of this manual for more information.

Custom Engineering Units

The I/O configuration web pages allow you to customize the process variable engineering units (EGU). The data can then be viewed on the *Process Status* page with the correct units.

Sensor Trimming

The AIM can be trimmed with two data points within the selected zero and span measurement range. This allows a complete range to be monitored, while placing a measurement emphasis on the most critical segment of the process range.

To perform sensor trimming, follow the steps below.

1. Select the channel you wish to trim; click the *Trim / Enable* link on the associated web page.
2. Click the *Trimming enabled* checkbox. Depending on your function, select *1 point trim* or *2 point trim*.
3. To trim the lower point, enter the value that you would like displayed as your process variable (PV) into the *Lower* text box. Input that value into the AIM using your input device.

4. Click the *Trim Lower* button. This will bring up a pop-up window to input the value that you entered as your lower trim point; click *Accept* if you are satisfied with the data received by the AIM.

The captured value will update to this value on the *Analog Input Trimming* screen.

5. If performing 2 point trimming, repeat Steps 4 and 5 for the upper trim point.
6. Click *Submit* to save the trimming values and continue to the next channel.

Repeat these steps for each channel that requires trimming.

Commit/Cancel Buttons

Click *Commit* when you are finished selecting parameters to save the settings to memory. *Cancel* ends your configuration without saving changes.

Figure 16. AIM Configuration Web Page

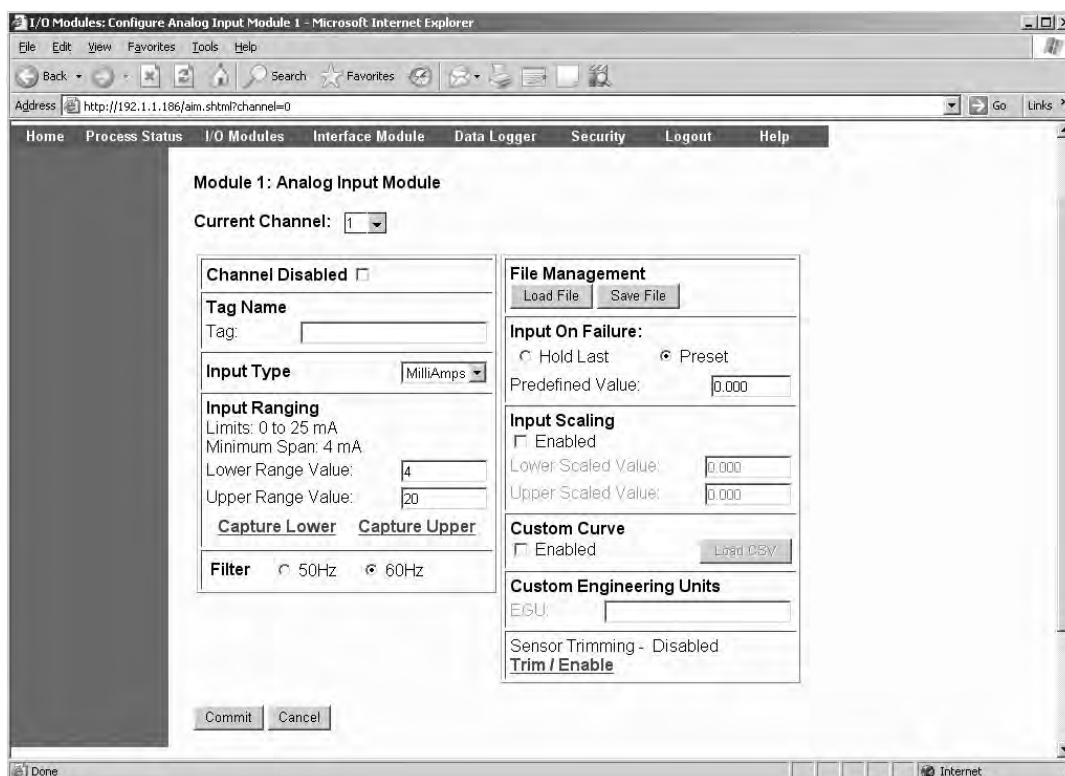

CPMS – TIM

Cathodic Protection Monitoring System
Temperature Input Module

The TIM Temperature Input Module

The Temperature Input Module (TIM) of the NCS family isolates and conditions up to four temperature signals and relays temperature information from these inputs to the Interface Module.

Installing the TIM

Installation consists of physically mounting the unit, completing the input connections, and grounding the unit.

Mounting

The TIM is designed to snap easily onto 35mm Top Hat (EN50022) DIN- rails. Snap the TIM onto the DIN-rail to the right of the CPMS module, then slide it along the rail until the DB25 connectors on the side of the TIM connect completely with the unit to its left. See Figure 18 for illustration.

Recommended Ground Wiring Practices

Moore Industries recommends the following ground wiring practices:

- Any Moore Industries product in a metal case or housing should be grounded.
- The CPMS individual module bases are mechanically grounded when installed onto the DIN-rail. Be sure the DIN-rail is connected to a system safety earth ground before making any other connections.
- All input signals to, and output signals from, Moore Industries' products should be wired using a shielded, twisted pair technique. Shields are to be connected to an earth or safety ground near the unit itself.
- The maximum length of unshielded input and output signal wiring should be 2 inches.

Input Connections

After mounting, you are ready to connect the inputs to the TIM. Since the TIM receives power from the connected Interface Module, only the temperature sensor inputs need to be connected. Figure 18 shows the connection diagrams for the TIM.

CE Conformity

Installation of any Moore Industries' product that carries the CE compliance marking (Commission Electro technique) must adhere to their respective installation guidelines in order to meet the requirements set forth in applicable EMC (Electromagnetic Compatibility) directive (EN61326). Consult the factory for additional information.

Configuring the TIM

The TIM is configured using the web server contained within the connected Interface Module. To configure the TIM, you must first mount it to the Interface Module as described in *Installing the TIM*. To access real-time data using MODBUS commands instead of the web server, see the *MODBUS/TCP Support* section of this manual.

After mounting, bring up the CPMS configuration software by starting an Internet browser on a computer attached to the same network as the CPMS, and typing *http://* followed by the IP address that the Moore Industries' NAC Client software lists for your Interface Module.

Once you have accessed the CPMS configuration software, click on *I/O Module*, then *Configure Temperature Input Module*. Configure the parameters listed on the screen, and when you are finished, press *Commit*.

The following sections describe parameters of the configuration web page.

Specifications

TIM Temperature Input Module (4 Channels) (Up to Eight Per Interface Module)

<p>Performance</p> <p>Input Ranges: See Table 8 Accuracy: See Table 8 Reference Junction Compensation Accuracy: ±0.25°C Input Resolution: 20-bit Stability (% of maximum span): RTD: 1-year, 0.013%; 3-year, 0.023%; 5-year, 0.029% Thermocouple: 1-year, 0.0084%; 3-year, 0.015%; 5-year, 0.019% Isolation: 500Vrms, continuous, from channel to channel, from each channel to case, and from each channel to terminals of other attached CPMS modules; will withstand 1000Vrms dielectric strength test for one minute, with no breakdown, from each channel to case, and from each channel to terminals of other attached CPMS modules Scan Time: The time required for the Interface Module to access process</p>	<p>Performance (continued)</p> <p>variable and status data from all four channels of the TIM is 16ms Response Time: 150ms Input Impedance (T/C): 40Mohms, nominal Maximum Input Overrange: ±5Vdc peak, maximum Excitation Current (RTD and Ohms): 250 microamps nominal Power Supply: Power is supplied by the Interface Module, 1.5W maximum Linearization Capability: Custom curve tables can be configured with up to 128 points using Internet Explorer web pages or PC-based software Input Filter: Programmable for 50 or 60Hz noise rejection Diagnostic Information: Refer to Table 15</p> <p>Status and Fault Indicators</p> <p>One red/green LED per channel indicates proper channel operation (green) or that the channel is in a fault condition (red)</p>	<p>Ambient Conditions</p> <p>Operating Range: –40°C to +85°C (–40°F to +185°F) Storage Range: –40°C to +85°C (–40°F to +185°F)</p> <p>Ambient Temperature Effect: See Table 1 Effect on Reference Junction Compensation: ±0.005°C/°C Relative Humidity: 0-95%, non-condensing RFI/EMI Immunity: 20V/m @20-1000MHz, 1kHz AM when tested according to ENC6100-4-3-1996; Effect on RTD/Ohms Input: 0.4°C/0.1 ohms, maximum; Effect on Thermocouple/Millivolt Input: 1.0°C/40 microvolts, maximum Common Mode Rejection: 100dB@50/60Hz Normal Mode Rejection: 50dB typical@0.2V peak-to-peak, 50/60Hz</p> <p>Weight 589 g (20.7 oz)</p>
---	---	---

Figure 17. TIM Dimensions

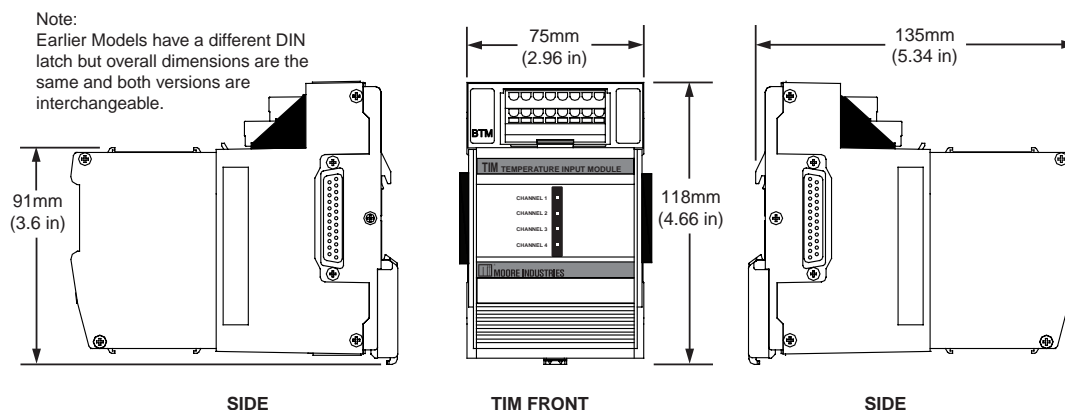

CPMS – TIM

Cathodic Protection Monitoring System
Temperature Input Module

Table 8. TIM Temperature Input Type and Accuracy Table

Input	Type	α	Ohms	Conformance Range	Minimum Span	Input Accuracy	Maximum Range	Ambient Temperature Accuracy/ $^{\circ}$ C Change
RTD (2-, 3-, 4-Wire)	Platinum	0.003850	100	-200 to 850 $^{\circ}$ C -328 to 1562 $^{\circ}$ F	10 $^{\circ}$ C (18 $^{\circ}$ F)	\pm 0.1 $^{\circ}$ C (\pm 0.18 $^{\circ}$ F)	-240 to 960 $^{\circ}$ C -400 to 1760 $^{\circ}$ F	0.0035 $^{\circ}$ C (0.0063 $^{\circ}$ F)
			200					
			300					
			400					
			500					
		1000						
		0.003902	100	-100 to 650 $^{\circ}$ C -148 to 1202 $^{\circ}$ F			-240 to 580 $^{\circ}$ C -400 to 1076 $^{\circ}$ F	
			200					
			400					
			500					
1000								
0.003916	100	-200 to 510 $^{\circ}$ C -328 to 950 $^{\circ}$ F	-240 to 580 $^{\circ}$ C -400 to 1076 $^{\circ}$ F					
Nickel	0.00672	120	-80 to 320 $^{\circ}$ C -112 to 608 $^{\circ}$ F	\pm 0.14 $^{\circ}$ C (\pm 0.25 $^{\circ}$ F)	-100 to 360 $^{\circ}$ C -148 to 680 $^{\circ}$ F	0.002 $^{\circ}$ C (0.0036 $^{\circ}$ F)		
Copper	0.00427	9.035	-50 to 250 $^{\circ}$ C -58 to 482 $^{\circ}$ F	\pm 1.6 $^{\circ}$ C (\pm 2.88 $^{\circ}$ F)	-65 to 280 $^{\circ}$ C -85 to 536 $^{\circ}$ F	0.0035 $^{\circ}$ C (0.0063 $^{\circ}$ F)		
Ohms	Direct Resistance	n/a	0-4000 ohms	0-4000 ohms	10 ohms	\pm 0.4 ohms	0-4095 ohms	0.002 ohms + 0.005% of reading
	Potentiometer		100-4000 ohms	0-100%	10%	\pm 0.1%	0-100%	
T/C	J	n/a	n/a	-180 to 760 $^{\circ}$ C -292 to 1400 $^{\circ}$ F	35 $^{\circ}$ C (63 $^{\circ}$ F)	\pm 0.25 $^{\circ}$ C (\pm 0.45 $^{\circ}$ F)	-210 to 770 $^{\circ}$ C -346 to 1418 $^{\circ}$ F	0.00016 $^{\circ}$ C + 0.005% of reading
	K	n/a	n/a	-150 to 1370 $^{\circ}$ C -238 to 2498 $^{\circ}$ F	40 $^{\circ}$ C (72 $^{\circ}$ F)	\pm 0.3 $^{\circ}$ C (\pm 0.54 $^{\circ}$ F)	-270 to 1390 $^{\circ}$ C -454 to 2534 $^{\circ}$ F	0.0002 $^{\circ}$ C + 0.005% of reading
	E	n/a	n/a	-170 to 1000 $^{\circ}$ C -274 to 1832 $^{\circ}$ F	35 $^{\circ}$ C (63 $^{\circ}$ F)	\pm 0.25 $^{\circ}$ C (\pm 0.45 $^{\circ}$ F)	-270 to 1013 $^{\circ}$ C -454 to 1855.4 $^{\circ}$ F	0.00026 $^{\circ}$ C + 0.005% of reading
	T	n/a	n/a	-170 to 400 $^{\circ}$ C -274 to 752 $^{\circ}$ F	35 $^{\circ}$ C (63 $^{\circ}$ F)	\pm 0.25 $^{\circ}$ C (\pm 0.45 $^{\circ}$ F)	-270 to 407 $^{\circ}$ C -454 to 764.6 $^{\circ}$ F	0.0001 $^{\circ}$ C + 0.005% of reading
	R	n/a	n/a	0 to 1760 $^{\circ}$ C 32 to 3200 $^{\circ}$ F	50 $^{\circ}$ C (90 $^{\circ}$ F)	\pm 0.55 $^{\circ}$ C (\pm 0.99 $^{\circ}$ F)	-50 to 1786 $^{\circ}$ C -58 to 3246.8 $^{\circ}$ F	0.00075 $^{\circ}$ C + 0.005% of reading
	S	n/a	n/a	0 to 1760 $^{\circ}$ C 32 to 3200 $^{\circ}$ F	50 $^{\circ}$ C (90 $^{\circ}$ F)	\pm 0.55 $^{\circ}$ C (\pm 0.99 $^{\circ}$ F)	-50 to 1786 $^{\circ}$ C -58 to 3246.8 $^{\circ}$ F	0.00075 $^{\circ}$ C + 0.005% of reading
	B	n/a	n/a	400 to 1820 $^{\circ}$ C 752 to 3308 $^{\circ}$ F	75 $^{\circ}$ C (135 $^{\circ}$ F)	\pm 0.75 $^{\circ}$ C (\pm 1.35 $^{\circ}$ F)	200 to 1836 $^{\circ}$ C 392 to 3336.8 $^{\circ}$ F	0.0038 $^{\circ}$ C + 0.005% of reading
	N	n/a	n/a	-130 to 1300 $^{\circ}$ C -202 to 2372 $^{\circ}$ F	45 $^{\circ}$ C (81 $^{\circ}$ F)	\pm 0.4 $^{\circ}$ C (\pm 0.72 $^{\circ}$ F)	-270 to 1316 $^{\circ}$ C -454 to 2400.8 $^{\circ}$ F	0.0003 $^{\circ}$ C + 0.005% of reading
	C	n/a	n/a	0 to 2300 $^{\circ}$ C 32 to 4172 $^{\circ}$ F	100 $^{\circ}$ C (180 $^{\circ}$ F)	\pm 0.8 $^{\circ}$ C (\pm 1.44 $^{\circ}$ F)	0 to 2338 $^{\circ}$ C 32 to 4240.4 $^{\circ}$ F	0.00043 $^{\circ}$ C + 0.005% of reading
mV	DC	n/a	n/a	-50 to 1000mV	4 mV	15 microvolts	n/a	0.5 microvolts + 0.005%

CPMS – TIM

Cathodic Protection Monitoring System
Temperature Input Module

Figure 18. TIM Connection Diagram

Refer to Figure 31 for Terminal Designations

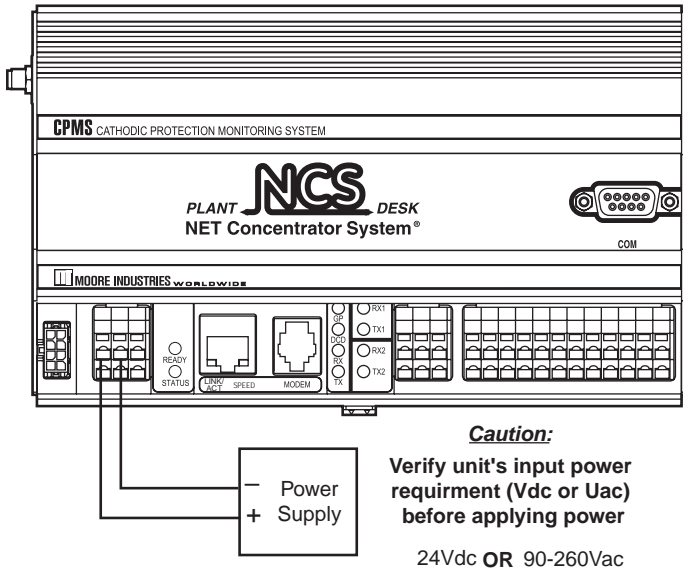

Input Connections
Attach the temperature inputs to the terminals at the top of the TIM. Specific connection types are shown below.

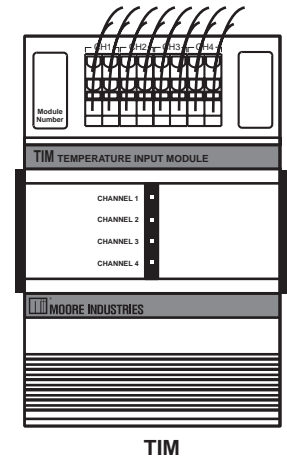

Connecting the TIM
Slide the external I/O module along the DIN-Rail until the DB25 link connects to the adjacent module

Terminal Connections

Thermocouple

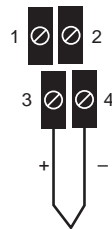

Millivolt

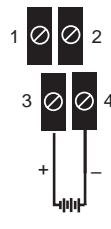

Potentiometer

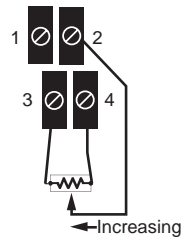

2-Wire RTD & Direct Resistance

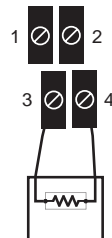

3-Wire RTD & Direct Resistance

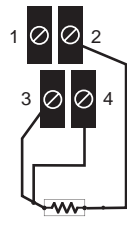

4-Wire RTD & Direct Resistance

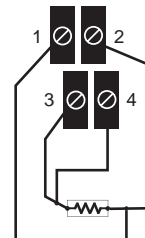

CPMS – TIM

Cathodic Protection Monitoring System Temperature Input Module

Current Channel

The TIM accepts four different temperature inputs, and uses a separate channel for each. Select the channel you wish to program.

Channel Disabled

Checking this box will cause the TIM and its associated Interface Module to ignore the selected channel, allowing you to use less than all four channels without receiving error messages.

Tag Name

Assign tag names, or descriptors, to process variables. The *Process Status* page will display the data next to the respective process variable tag.

Input Configuration

This programs the type of input that the TIM will receive. Different measurement types require different parameters to be programmed. When a measurement type is selected, other parameters may become red, indicating that these parameters must be programmed.

Input Ranging

Allows you to either input or capture the upper and lower ranges that you want to have measured.

Ambient Temperature

Checking this box causes the TIM to measure the temperature at the RJC sensor and causes the attached Interface Module to scan this value from the TIM. The temperature is stored in a modbus register titled *Ambient Temperature* and cannot be accessed through the web server. To access this register, refer to the *MODBUS/TCP Support* section of this manual.

File Management

If you will be using a common configuration within your system, you can create a configuration and save it to a file so that you can load it into another I/O module. Refer to the *File Management* section of this manual for more information.

Broken Wire Detection

Checking this causes the TIM to perform continuous

sensor diagnostics, monitoring the sensor and sending the output upscale or downscale during a failure.

PV Input On Failure

Select how your input value reacts upon a failure. Selecting *Hold Last* maintains the value last read before the failure. To display a user-selected value, click the *Preset* button and then enter the value into the *Predefined Value* text box. The unit displayed will depend upon the *Input Type* that you have chosen.

Input Scaling

Input Scaling allows you to take the input and convert it to a different range. For example, you take a channel with a 0-1000°C range and scale it to 0-100°C; now when the input is 734°C, it is relayed to the Interface Module as 73.4°C.

Custom Curve

The Custom Curve box allows you to setup a custom linearization table of up to 128 points that will tell the TIM what value to output when a certain input is received. This is accomplished by loading into memory a *comma-separated value* file (.csv) that was created in Excel® or a similar program. Refer to the *Loading a Custom Curve File* section of this manual for more information.

Custom Engineering Units

The I/O configuration web pages allow you to customize the process variable engineering units (EGU). The data can then be viewed on the *Process Status* page with the correct units.

Sensor Trimming

The TIM can be trimmed with two data points within the selected zero and span measurement range.

This allows a complete range to be monitored, while placing a measurement emphasis on the most critical segment of the process range.

Follow the steps below trim your instrument.

1. Select the channel you wish to trim; click the *Trim / Enable* link on the associated web page.
2. Click the *Trimming enabled* checkbox. Depending on your function, select *1 point trim* or *2 point trim*.
3. To trim the lower point, enter the value that you would like displayed as your process variable (PV) into the *Lower* text box. Input that value into the TIM using your input device.
4. Click the *Trim Lower* button. This will bring up a pop-up window to input the value that you entered as your lower trim point; click *Accept* if you are satisfied

with the data received by the TIM.

The captured value will update to this value on the *Analog Input Trimming* screen.

5. If performing 2 point trimming, repeat Steps 4 and 5 for the upper trim point.
6. Click *Submit* to save the trimming values and continue to the next channel.

Repeat these steps for each channel that requires trimming.

Commit/Cancel Buttons

Click *Commit* when you are finished selecting parameters to save the settings to memory. *Cancel* ends your configuration without saving changes.

Figure 19. TIM Configuration Web Page

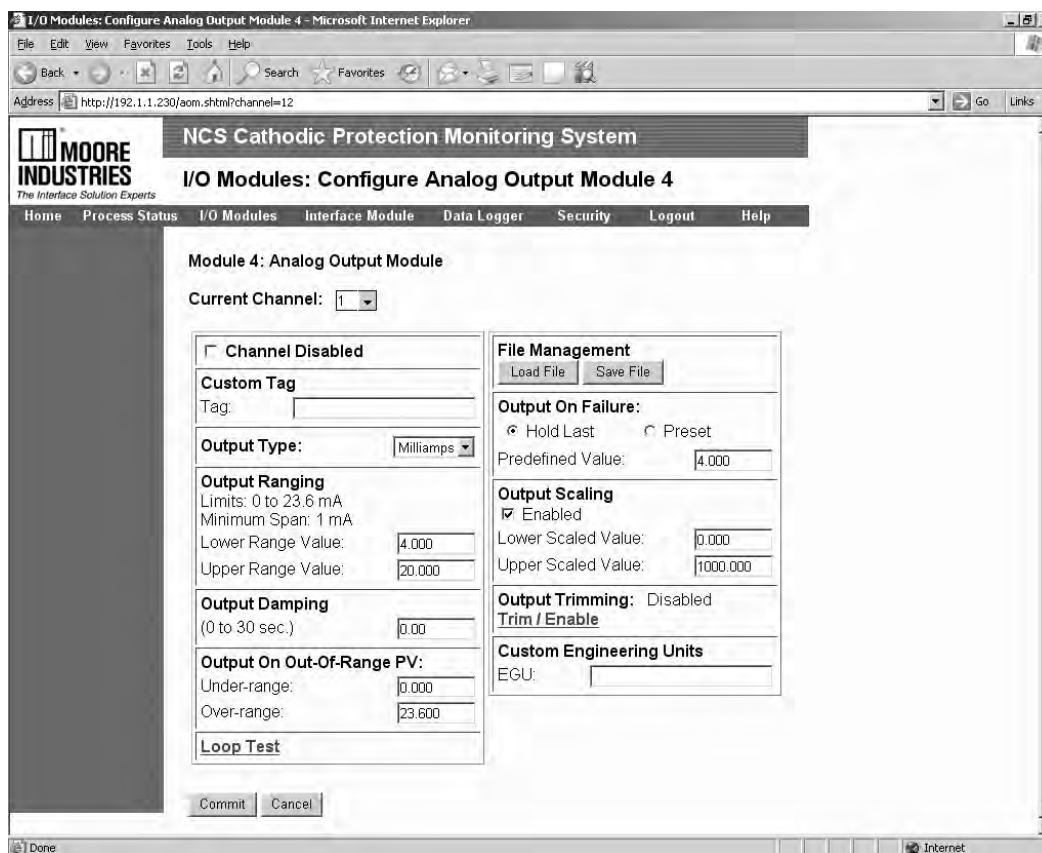

CPMS – AOM

Cathodic Protection Monitoring System
Analog Output Module

The AOM Analog Output Module

The Analog Output Module (AOM) accepts information from the CPMS and outputs it as one of four independently configurable analog signals.

Installing the AOM

Installation consists of physically mounting the unit, completing the output connections, and grounding the unit.

Mounting

The AOM is designed to snap easily onto 35mm Top Hat (EN50022) DIN- rails. Snap the AOM onto the DIN-rail to the right of the CPMS unit, then slide it along the rail until the DB25 connectors on the side of the AOM connect completely with the unit to its left. See Figure 21 for illustration.

Recommended Ground Wiring Practices

Moore Industries recommends the following ground wiring practices:

- Any Moore Industries product in a metal case or housing should be grounded.
- The CPMS individual module bases are mechanically grounded when installed onto the DIN-rail. Be sure the DIN-rail is connected to a system safety earth ground before making any other connections.
- All input signals to, and output signals from, Moore Industries' products should be wired using a shielded, twisted pair technique. Shields are to be connected to an earth or safety ground at the unit itself.
- The maximum length of unshielded input and output signal wiring should be 2 inches.

Input and Output Connections

After mounting, it is time to connect the analog outputs to the AOM. Since the AOM receives power from the connected Interface Module, only the analog outputs need to be connected. Figure 21 shows the connection diagrams for an AOM.

CE Conformity

Installation of any Moore Industries' product that carries the CE compliance marking (Commission Electro technique) must adhere to their respective installation guidelines in order to meet the requirements set forth in applicable EMC (Electromagnetic Compatibility) directive (EN61326). Consult the factory for additional information.

Configuring the AOM

The AOM is configured using the web server contained within the Interface Module it is attached to. To configure the AOM, you must first mount it to the Interface Module as described in *Installing the AOM*. To access real-time data using MODBUS commands instead of a web server, see the *Modbus/TCP Support* section of this manual.

After mounting, bring up the CPMS configuration software by starting an Internet browser on a computer attached to the same network as the CPMS, and typing *http://* followed by the IP address that the Moore Industries NAC Client software lists for your Interface Module.

Once you have accessed the CPMS configuration software, click on *I/O Module*, then *Configure Analog Output Module*. Configure the parameters listed on the screen, and when you are finished, press *Commit*.

The following sections describe parameters of the configuration web page.

Current Channel

The AOM comes standard with four channels, each independently configurable to handle current or voltage. Select the channel you wish to program.

Specifications

AOM Analog Output Module (4 Channels) Up to Eight per Interface Module

<p>Performance</p> <p>Output Ranges: Programmable for any range within: Current (sink or source), 0-20mA or Voltage, 0-10V</p> <p>Accuracy: $\pm 0.015\%$ of maximum span</p> <p>Output Resolution: 18-bit</p> <p>Stability (% of max. span): Current: 1-year, 0.012%; 3-year, 0.020%; 5-year, 0.026%</p> <p>Voltage: 1-year, 0.066%; 3-year, 0.11%; 5-year, 0.15%</p> <p>Isolation: 500Vrms, continuous, from channel to channel, from each channel to case, and from each channel to terminals of other attached CPMS modules; will withstand 1000Vrms dielectric strength test for one minute, with no breakdown, from each channel to case, and from each channel to terminals of other attached CPMS modules</p> <p>Scan Time: The time required for the Interface Module to access process variable and status data from all four channels of the AOM is 16ms</p>	<p>Performance (continued)</p> <p>Response Time: 50ms to 90% of final value on a step input</p> <p>Output Damping: Increases response time by adjusting filter time constant from 0-30 seconds</p> <p>Ripple: Current, 10mV peak-to-peak measured across a 250ohm load resistor; Voltage, 50mV peak-to-peak maximum</p> <p>Load Capability: Current, 0-1000ohms (source), 42V maximum (sink) 1500ohms; Voltage, 0-5mA (2000 ohms minimum load)</p> <p>Output Limiting: Current output is guaranteed up to 21.6mA (or 10% of full scale above the programmed full value) and limits at 23.6mA; Voltage output accuracy is guaranteed up to 10.5V (or 5% of full scale above the programmed full value) and limits at 11.0V</p> <p>Load Effect (current outputs): 0.01% of span from 0 to maximum load resistance on current output</p>	<p>Performance (continued)</p> <p>Output Failure Mode: Outputs are programmable to either hold last value or go to a pre-defined value on error upon lost communication with the Interface Module or upon receiving invalid primary variable data</p> <p>Power Supply: Power is supplied by the Interface Module, 4W maximum</p> <p>Diagnostic Information: Refer to Table 16</p> <p>Status and Fault Indicators One red/green LED per channel indicates proper channel operation (green) or that the channel is in a fault condition (red)</p> <p>Ambient Conditions</p> <p>Operating Range: -40°C to +85°C (-40°F to +185°F)</p> <p>Storage Range: -40°C to +85°C (-40°F to +185°F)</p> <p>Ambient Temperature Effect: 0.01% of maximum span/°C</p> <p>Relative Humidity: 0-95%, non-condensing</p> <p>RFI/EMI Protection: 20V/m@20-1000MHz, 1kHz AM when tested according to ENC61000-4-3-1996</p> <p>Weight 765 g (27 oz)</p>
---	--	---

Specifications and information subject to change without notice.

Figure 20. AOM Dimensions

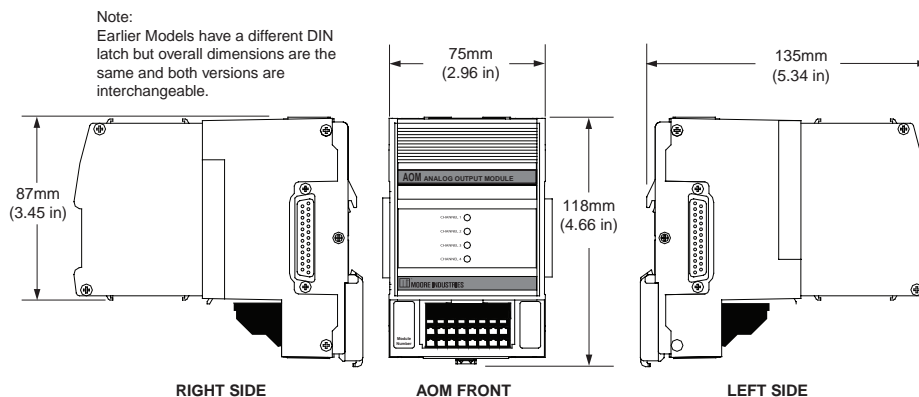

CPMS – AOM

Cathodic Protection Monitoring System
Analog Output Module

Figure 21. AOM Connection Diagram

Refer to Figure 31 for Terminal Designations

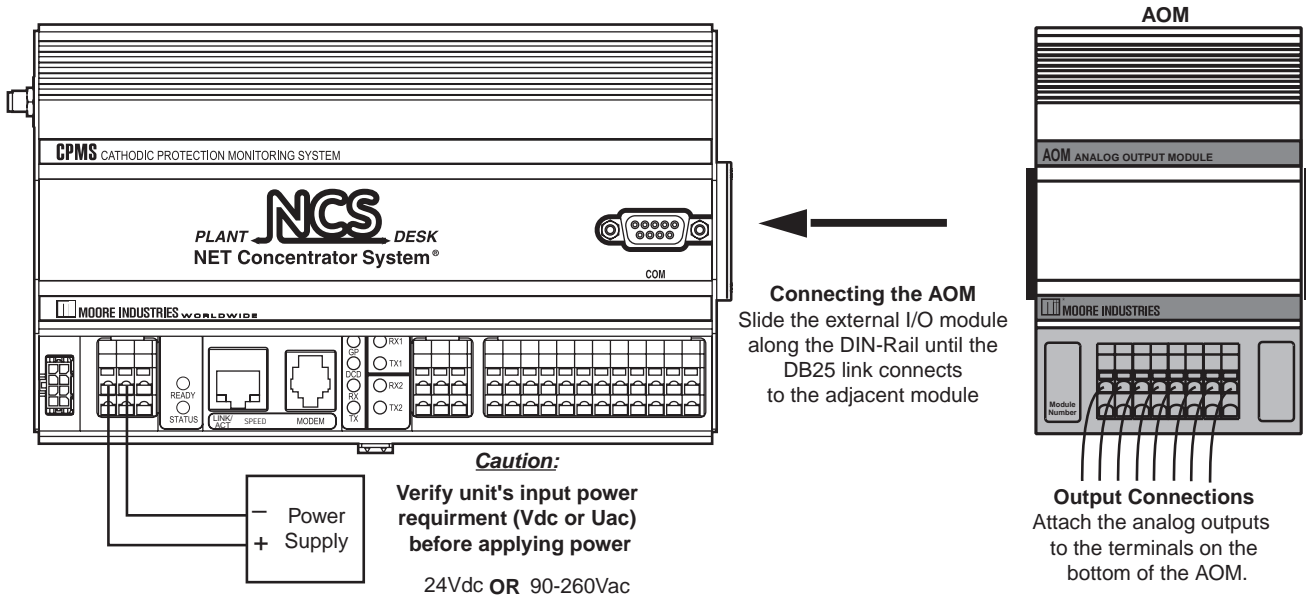

Terminal Connections

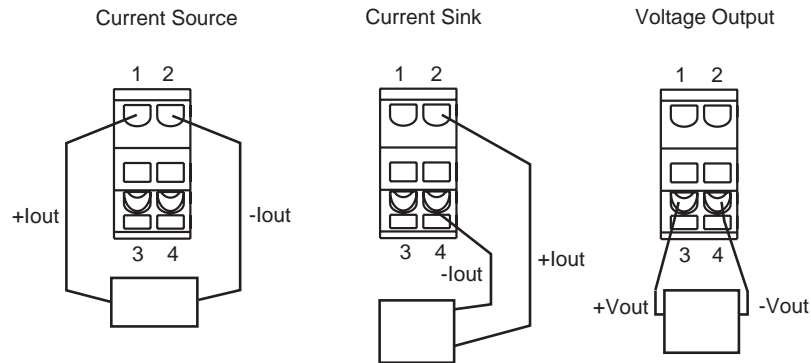

NOTE: To install wires into the terminals, insert a small, flathead screwdriver into the pry slot, open wire terminal and place wire.

Figure 22. AOM Configuration Web Page

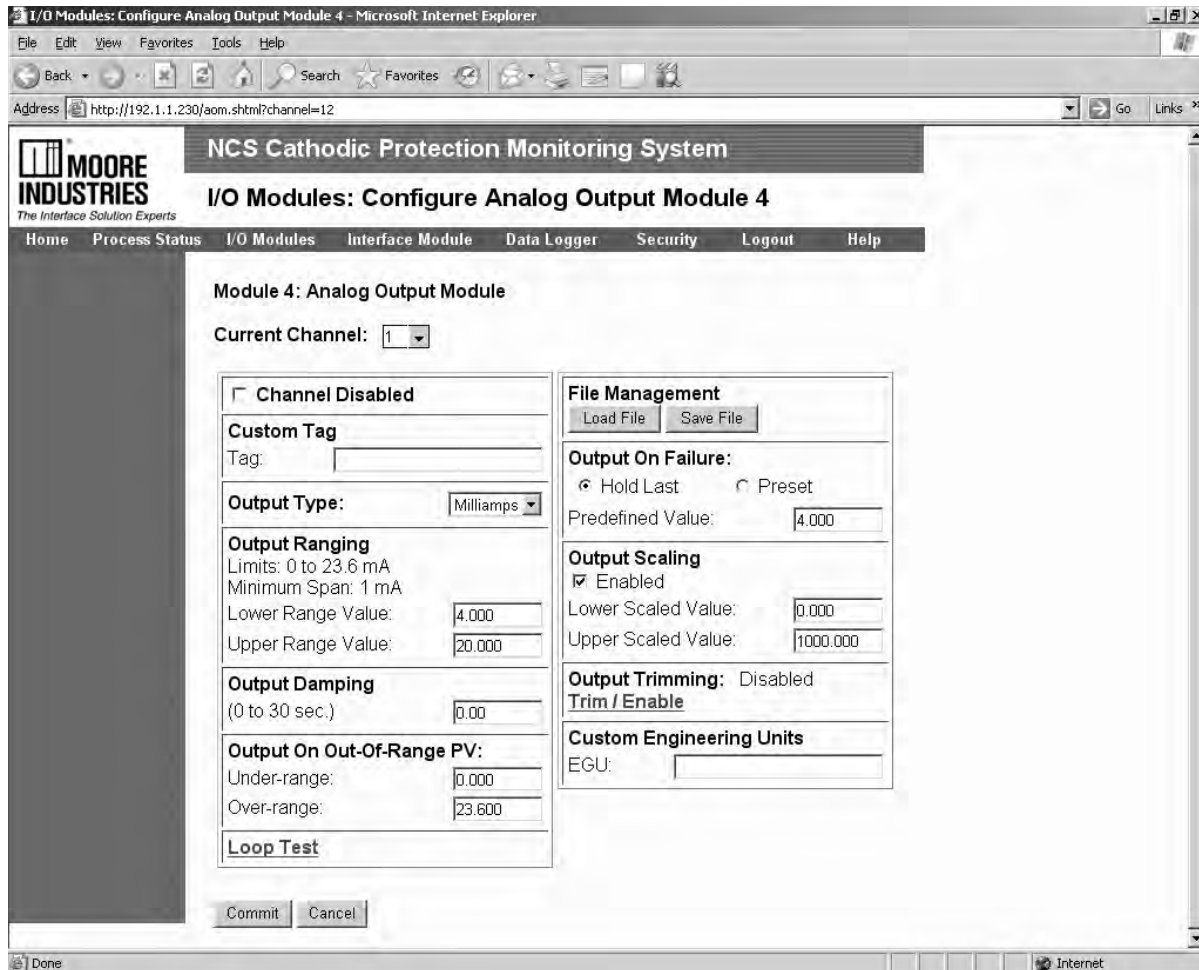

CPMS – AOM

Cathodic Protection Monitoring System

Analog Output Module

Custom Tag

Assign tag names, or descriptors, to process variables. The *Process Status* page will display the data next to the respective process variable tag.

Channel Disabled

Checking this box will cause the AOM and its associated Interface Module to ignore the selected channel, allowing you to use less than all four channels without receiving error messages.

Output Type

This programs the AOM to output either volt or mA. When an *Output Type* is selected, other parameters may become red, indicating that these parameters must be programmed.

Output Ranging

Allows you to input the upper and lower ranges that you want the AOM to output.

Output Damping

The Output Damping allows you to introduce a delay into the AOM's response to a change in input. The value of the output damping is the number of seconds that it will take for a display to make a 63% change in response to the change in input. A damping time of "0" will disable damping.

Output on Out-of-Range PV

These boxes allow you to enter the value that you want the AOM's output to default to when the monitored input goes out of range.

Loop Test

This function allows you test the other instruments on the loop by setting the AOM to output a specific value. After clicking *Loop Test*, use the arrows to select the desired value and press *Set Value* to begin.

File Management

If you will be using a common configuration within your system, you can create a configuration and save it to

a file so that you can load it into another I/O module. Refer to the *File Management* section of this manual for more information.

Output on Failure

This section tells the AOM what to do when the monitored input fails entirely. It will either maintain the last value (*Hold Last*), or jump to a predefined value that you input (*Preset Predefined Value*).

Output Scaling

Output Scaling allows you to access the analog output process variable in a number range more meaningful to you than the actual mA or Volts output. For example, if the actual output range is 4-20mA, set the scaled range to 0-100; you now write 0 to the process variable to get 4mA out and 100 to get 20mA out.

Output Trimming

The AOM can be trimmed with two data points within the selected zero and span output range. This allows a complete range to be output, while placing an emphasis on a specific segment of the range most critical to the process.

Custom Engineering Units

The I/O configuration web pages allow you to customize the process variable engineering units (EGU). The data can then be viewed on the *Process Status* page with the correct units.

Commit/Cancel Buttons

Click *Commit* when you are finished selecting parameters to save the settings to memory. *Cancel* ends your configuration without saving changes.

CPMS – CPM

Cathodic Protection Monitoring System
Net Concentrator® System Power Module

The CPM NET Concentrator System Power Module

The Interface Module provides power for two I/O modules. If additional modules are connected to the CPMS, a CPM Concentrator Power Module is required. It works in conjunction with the Interface Module to power CPMS stations of up to eight I/O modules.

If your CPMS is equipped with one Cathodic Input or Analog Input Module, then the CPMS can power one additional external module. You will require a CPM to power any additional modules.

If your CPMS is equipped with two Cathodic Input or Analog Input Modules, then CPMS power is used to power both internal modules. A CPM will be required to power any externally attached modules.

ACPMS can support a maximum of sixteen modules (including on-board modules), in which case two CPM modules would be required for power. This forms a fully populated system.

Note:

The CPMS Interface Module provides power for up to two I/O Modules. If more than two I/O Modules will be connected to the Interface Module, a CPM Concentrator Power Module is required. It works in conjunction with the CPMS to power stations of up to eight I/O Modules. However, the CPM will only power units that are mounted to **its** left (from the user's front-view perspective, this would be the right side of the CPM).

Installing the CPM

Installation consists of physically mounting the unit, making the power connections, and grounding the unit.

Mounting

The CPM is designed to snap easily onto 35mm Top Hat (EN50022) DIN- rails. Snap the CPM onto the DIN-rail to the right of any module within the CPMS station, then slide it along the rail until the DB25 connectors on the side of the CPM connect completely with the unit to its left.

Figure 23. CPM Connection Diagram

Refer to Figure 31 for Terminal Designations

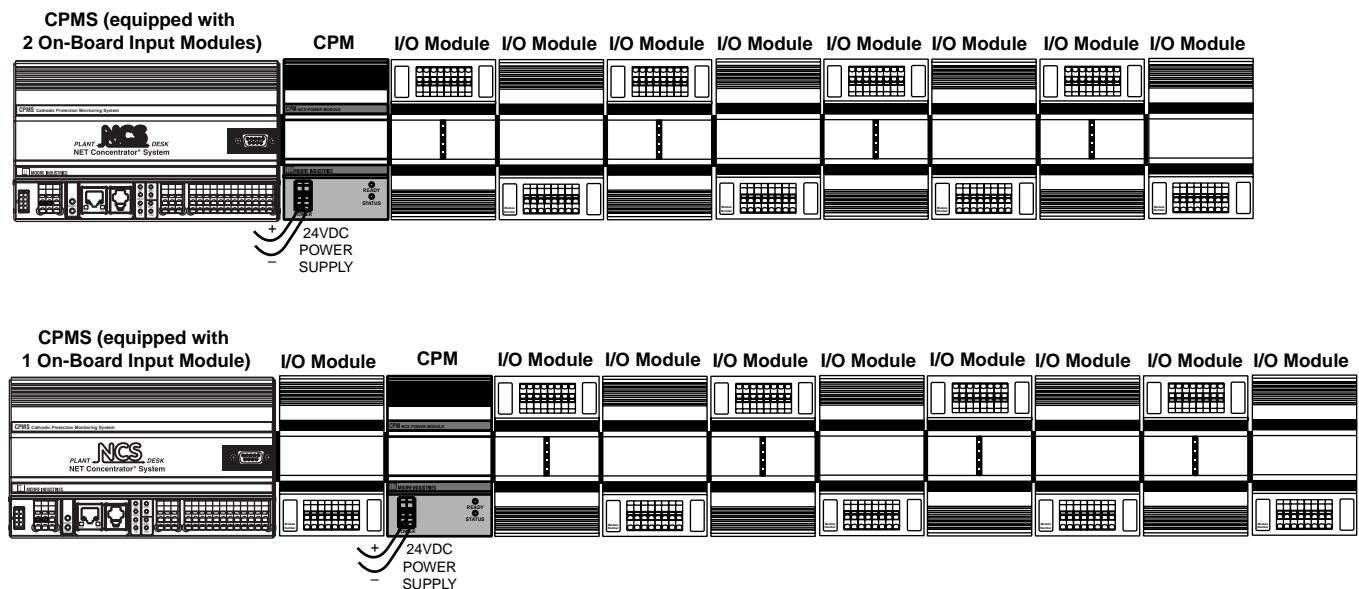

CPMS – CPM

Cathodic Protection Monitoring System
Net Concentrator® System Power Module

The CPM can be installed at any position within a system. However, keep in mind that the CPM only provides power to units on its left, therefore proper placement must be performed to provide power to the allowed number of I/O modules.

Recommended Ground Wiring Practices

Moore Industries recommends the following ground wiring practices:

- Any Moore Industries product in a metal case or housing should be grounded.
- The CPMS individual module bases are mechanically grounded when installed onto the DIN-rail. Be sure the DIN-rail is connected to a system safety earth ground before making any other connections.
- The maximum length of unshielded input and output signal wiring should be 2 inches.

Power Connections

After mounting, power up the CPM. Attach 20-30Vdc power as shown in Figure 23.

Power Sourcing Parameters for General Locations, Intrinsically Safe, and Non-Incendive/Type N applications

In accordance with IEC 1010.1 Annex H (all models), the input terminals must be connected to and/or supplied from a certified energy limiting Class 2 or a Separate Extra Low Voltage (S.E.L.V.) power supply separated from all mains by double/reinforced insulation.

CE Conformity

Installation of any Moore Industries' product that carries the CE compliance marking (Commission Electro technique) must adhere to their respective installation guidelines in order to meet the requirements set forth in applicable EMC (Electromagnetic Compatibility) directive (EN61326). Consult the factory for additional information.

CPMS – DIM

Cathodic Protection Monitoring System
Discrete Input Module

The DIM Discrete Input Module

The Discrete Input Module (DIM) of the NCS family isolates and conditions up to eight discrete signals, and relays input information to the Interface Module. The DIM is available for three different discrete input channel types: contact closure, high range voltage, or low range voltage.

Installing the DIM

Installation consists of physically mounting the unit, completing the input connections, and grounding the unit.

Mounting

The DIM is designed to snap easily onto 35mm Top Hat (EN50022) DIN- rails. Snap the DIM onto the DIN-rail to the right of the CPMS unit, then slide it along the rail until the DB25 connectors on the side of the DIM connect completely with the unit to its left. See Figure 26 for illustration.

Recommended Ground Wiring Practices

Moore Industries recommends the following ground wiring practices:

- Any Moore Industries product in a metal case or housing should be grounded.
- The NCS individual module bases are mechanically grounded when installed onto the DIN-rail. Be sure the DIN-rail is connected to a system safety earth ground before making any other connections.
- All input signals to, and output signals from, Moore Industries' products should be wired using a shielded, twisted pair technique. Shields are to be connected to an earth or safety ground near the unit itself.
- The maximum length of unshielded input and output signal wiring should be 2 inches.

Input Connections

After mounting, it is time to connect the discrete inputs to the DIM. Since the DIM receives power from the connected Interface Module, only the discrete inputs need to be connected. Figure 26 shows the connection diagrams for the DIM.

CE Conformity

Installation of any Moore Industries' product that carries the CE compliance marking (Commission Electro technique) must adhere to their respective installation guidelines in order to meet the requirements set forth in applicable EMC (Electromagnetic Compatibility) directive (EN61326). Consult the factory for additional information.

Specifications

DIM Discrete Contact Closure Input Module (8 Channels) Up to Eight Per Interface Module

<p>Performance Input Ratings: 24V/3.7mA, internally powered Input Logic Threshold: 8V low-going; 16V high-going Input Logic: Closed contact input yields logic 1 Isolation: 500Vrms, continuous, from channel to channel, from each channel to case, and from each channel to terminals of other attached CPMS modules; will withstand 1000Vrms dielectric strength test for one minute, with no breakdown, from each channel to case, and from</p>	<p>Performance (continued) each channel to terminals of other attached CPMS modules Scan Time: 16ms Response Time: <12ms with contact debounce disabled Power Supply: Power is supplied by the Interface Module, 3W maximum Diagnostic Information: Refer to Table 17</p> <p>LED Indicators One red/green LED per channel indicates input state, with red indicating open contact input</p>	<p>Ambient Conditions Operating Range: –40°C to +85°C (–40°F to +185°F) Storage Range: –40°C to +85°C (–40°F to +185°F) Relative Humidity: 0-95%, non-condensing RFI/EMI Protection: 20V/m @20-1000MHz, 1kHz AM when tested according to IEC1000-4-3-1995</p> <p>Weight 493 g (17.4 oz)</p>
--	--	---

DIM Discrete Voltage Input Module (8 Channels) Up to Eight Per Interface Module

<p>Performance Input Ratings: Low Range, 30Vac/Vdc; High Range: 120/240Vac/Vdc Input Logic Threshold: Low Range: <9Vac or DC guaranteed low, >15Vac or DC guaranteed high; High Range: <55Vac or dc guaranteed low, >90Vac or dc guaranteed high Input Logic: Input above threshold yields logic 1; Input below threshold yields logic 0 Input Impedance: Each input draws <4mA when on Isolation: 500Vrms, continuous, from channel to channel, from each channel to case, and from</p>	<p>Performance (continued) each channel to terminals of other attached CPMS modules; will withstand 1000Vrms dielectric strength test for one minute, with no breakdown, from each channel to case, and from each channel to terminals of other attached CPMS modules Scan Time: 16ms Response Time: <30ms Maximum Input Overrange: Up to 260Vac/Vdc Power Supply: Power is supplied by the Interface Module, 1W maximum Diagnostic Information: Refer to Table 17</p>	<p>LED Indicators One red/green LED per channel indicates input state, with red indicating input below threshold</p> <p>Ambient Conditions Operating Range: –40°C to +85°C (–40°F to +185°F) Storage Range: –40°C to +85°C (–40°F to +185°F) Relative Humidity: 0-95%, non-condensing RFI/EMI Protection: 20V/m @20-1000MHz, 1kHz AM when tested according to IEC1000-4-3-1995</p> <p>Weight 536 g (18.8 oz)</p>
---	---	---

Figure 25. DIM Dimensions

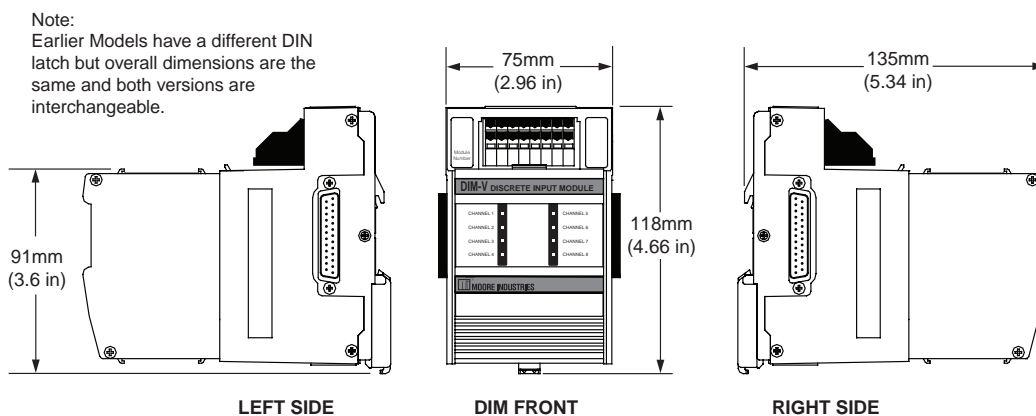

CPMS – DIM

Cathodic Protection Monitoring System
Discrete Input Module

Figure 26. DIM Connection Diagram

Refer to Figure 31 for Terminal Designations

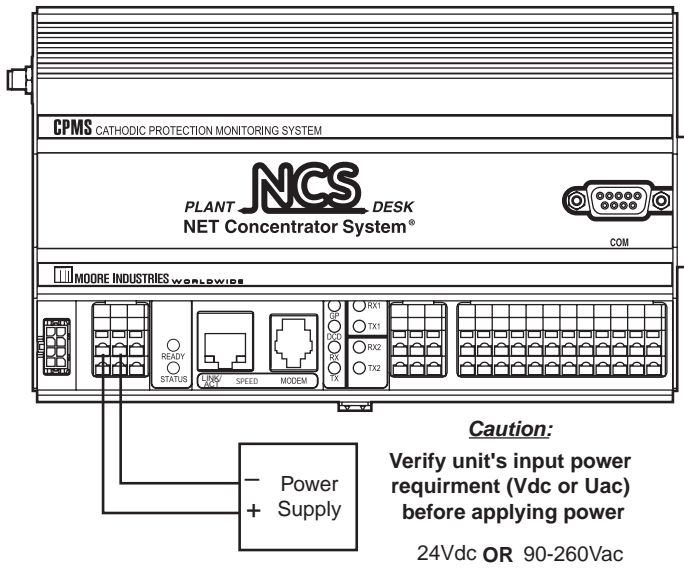

Input Connections
Attach the discrete inputs to the terminals at the top of the DIM.

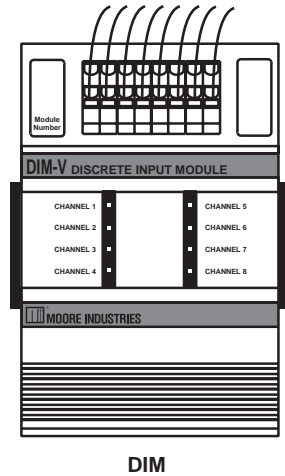

Connecting the DIM
Slide the external I/O module along the DIN-Rail until the DB25 link connects to the adjacent module

Terminal Connections (Typical)

Voltage Input

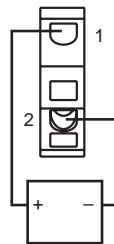

Contact Closure Input

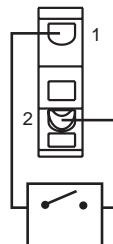

NOTE: To install wires into the terminals, insert a small, flathead screwdriver into the pry slot, open wire terminal and place wire.

Configuring the DIM

The DIM is configured using the web server contained within the Interface Module it is attached to. To configure the DIM, you must first mount it to the Interface Module as described in *Installing the DIM*. To access real-time data using modbus commands instead of the web server, see the *MODBUS/TCP Support* of this manual.

After mounting, bring up the NCS configuration software by starting an Internet browser on a computer attached to the same network as the CPMS, and typing *http://* followed by the IP address that the Moore Industries NAC Client software lists for your Interface Module.

Once you have accessed the NCS configuration software, click on *I/O Module*, then *Configure Discrete Input Module*.

Configure the parameters listed on the screen, and when you are finished, press *Commit*. See below for a description of the different parts of the screen.

The following sections describe parameters of the configuration web page.

Contact Debounce (Contact Closure DIM units only)

When some contacts open or close, there can be a short period of oscillation resulting from the

mechanical contacts. The *Contact Debounce* setting causes the NCS to ignore false signals caused by these oscillations. This setting is only available with contact closure DIM modules.

File Management

If you will be using a common configuration within your system, you can create a configuration and save it to a file so that you can load it into another I/O module. Refer to the *File Management* section of this manual for more information.

Tag

Assign a tag name, or descriptor, to process variables for each channel. The *Process Status* page will display the data next to the respective process variable tag.

Failure Response

This section tells the ROM what to do if communication with the Interface Module fails. It will either maintain the last value (*Hold*), or turn the relay to a predetermined energized or de-energized state (*On/Off*).

Commit/Cancel Buttons

Click *Commit* when you are finished selecting parameters to save the settings to memory. *Cancel* ends your configuration without saving changes.

Figure 27. DIM Configuration Web Page

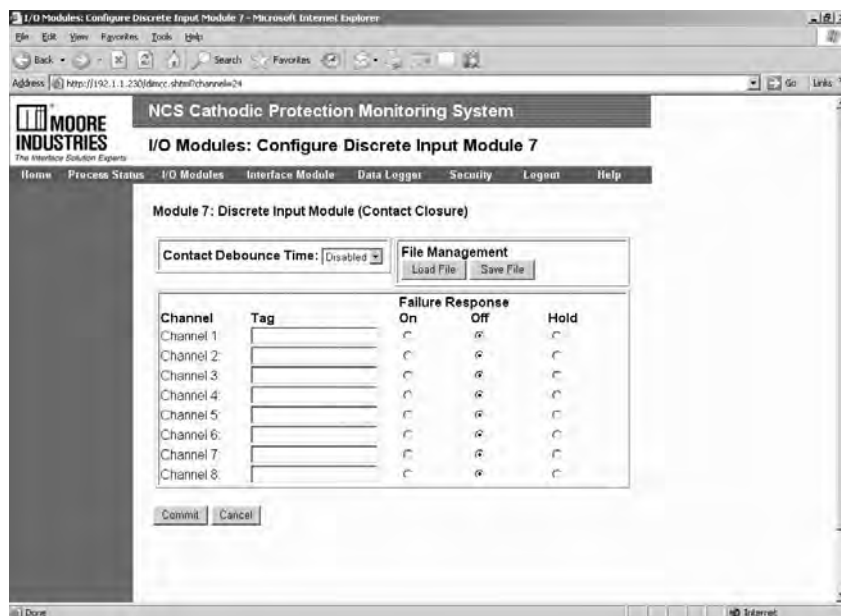

CPMS – ROM

Cathodic Protection Monitoring System
Relay Output Module

The ROM Relay Output Module

The Relay Output Module (ROM) accepts information from the CPMS and outputs it to either four or eight independently configurable relay signals.

Installing the ROM

Installation consists of physically mounting the unit, completing the output connections, and grounding the unit.

Mounting

The ROM is designed to snap easily onto 35mm Top Hat (EN50022) DIN- rails. Snap the ROM onto the DIN-rail to the right of the CPMS unit, then slide it along the rail until the DB25 connectors on the side of the ROM connect completely with the unit to its left. See Figure 29 for illustration.

Recommended Ground Wiring Practices

Moore Industries recommends the following ground wiring practices:

- Any Moore Industries product in a metal case or housing should be grounded.
- The CPMS individual module bases are mechanically grounded when installed onto the DIN-rail. Be sure the DIN-rail is connected to a system safety earth ground before making any other connections.
- All input signals to, and output signals from, Moore Industries' products should be wired using a shielded, twisted pair technique. Shields are to be connected to an earth or safety ground near the unit itself.
- The maximum length of unshielded input and output signal wiring should be 2 inches.

Input Connections

After mounting, it is time to connect the relay outputs to the ROM. Since the ROM receives power from the connected Interface Module, only the relay outputs need to be connected. Figure 29 shows the connection diagrams for a ROM.

CE Conformity

Installation of any Moore Industries' product that carries the CE compliance marking (Commission Electro technique) must adhere to their respective installation guidelines in order to meet the requirements set forth in applicable EMC (Electromagnetic Compatibility) directive (EN61326). Consult the factory for additional information.

CPMS – ROM

Cathodic Protection Monitoring System
Relay Output Module

Specifications

ROM Relay Output Module Up to Eight Per Interface Module

<p>Performance Mechanical Output Ratings: SPST relay, 1 form A or B, rated 2A@250Vac, 50/60Hz or 2A@30Vdc, non-inductive Output Logic: Logic 1 yields energized relay Output Failure Mode: Outputs are programmable to either hold last value, or go energized or de-energized upon lost communication with the Interface Module Scan Time: 16ms Isolation: 500Vrms, continuous, from channel to channel, from each channel to case, and from each channel to terminals of other</p>	<p>Performance (continued) attached CPMS modules; will withstand 1000Vrms dielectric strength test for one minute, with no breakdown, from each channel to case, and from each channel to terminals of other attached CPMS modules Response Time: <10ms Power Supply: Power is supplied by the Interface Module, 3W maximum Diagnostic Information: Refer to Table 17</p>	<p>LED Indicators One red/green LED per channel indicates relay state and can be programmed for desired sense</p> <p>Ambient Conditions Operating Range: –40°C to +85°C (–40°F to +185°F) Storage Range: –40°C to +85°C (–40°F to +185°F) Relative Humidity: 0-95%, non-condensing RFI/EMI Protection: 20V/m @20-1000MHz, 1kHz AM when tested according to IEC1000-4-3-1995</p> <p>Weight 493 g (17.4 oz)</p>
--	--	--

Figure 28. ROM Dimensions

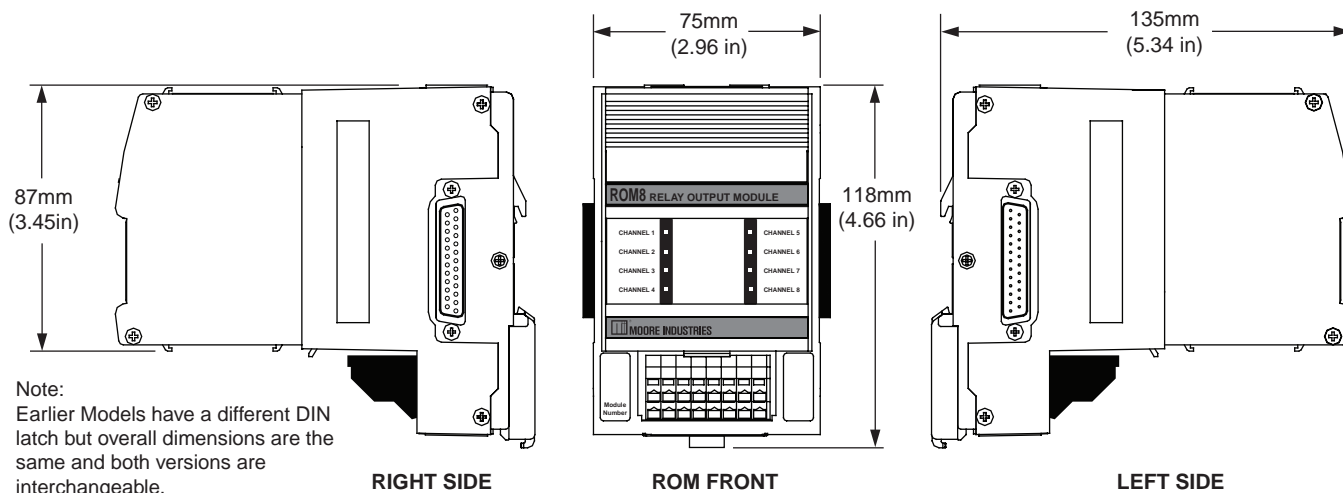

CPMS – ROM

Cathodic Protection Monitoring System
Relay Output Module

Figure 29. ROM Connection Diagram

Refer to Figure 31 for Terminal Designations

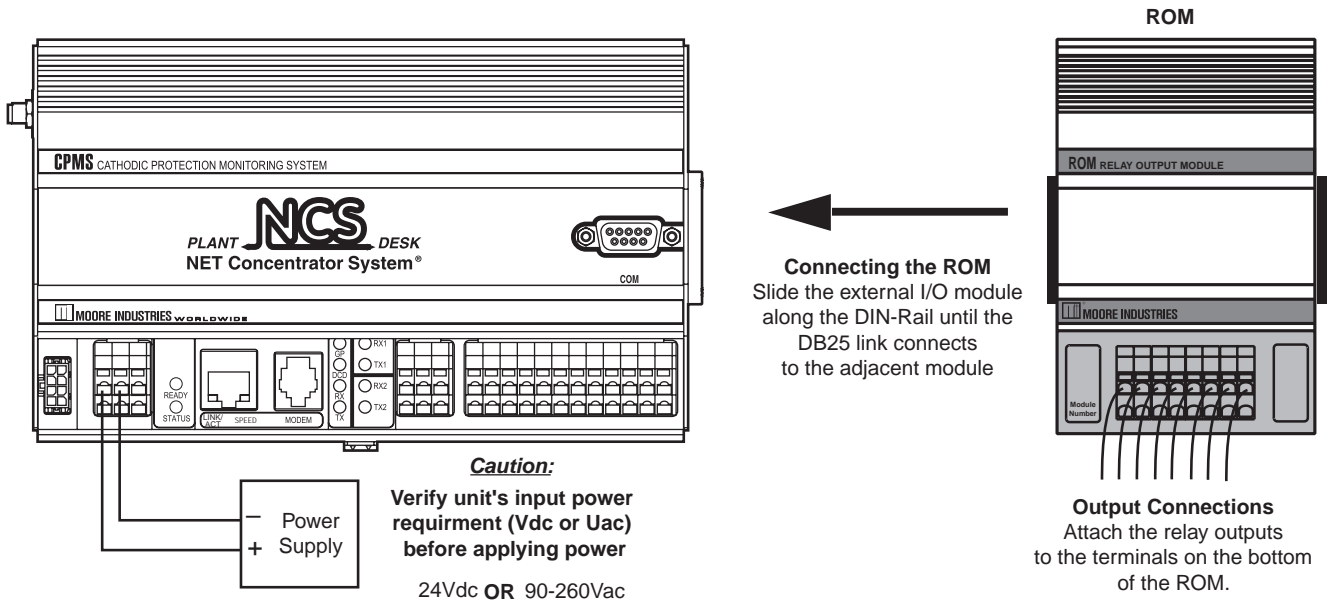

Terminal Connections

Relay Output

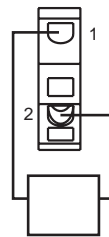

NOTE: To install wires into the terminals, insert a small, flathead screwdriver into the pry slot, open wire terminal and place wire.

Configuring the ROM

The ROM is configured using the web server contained within the Interface Module it is attached to. To configure the ROM, you must first mount it to the Interface Module as described in *Installing the ROM*. To access real-time data using Modbus commands instead of a web server, see the *MODBUS/TCP Support* section of this manual.

After mounting, bring up the CPMS configuration software by starting an Internet browser on a computer attached to the same network as the NCS, and typing *http://* followed by the IP address that the Moore Industries NAC Client software lists for your Interface Module.

Once you have accessed the CPMS configuration software, click on *I/O Module*, then *Configure Relay Output Module*.

Configure the parameters listed on the screen, and when you are finished, press *Commit*.

The following sections describe parameters of the configuration web page.

When energized, LEDs are:

Allows you to input the color (red or green) of the LED when the relay is energized.

File Management

If you will be using a common configuration within your system, you can create a configuration and save it to

a file so that you can load it into another I/O module. Refer to the *File Management* section of this manual for more information.

Tag

Assign a tag name, or descriptor, to process variables for each channel. The *Process Status* page will display the data next to the respective process variable tag.

Relay on Powerup

Checking a box configures the corresponding relay to be on (energized) upon power up for each channel for which you have checked the box.

Failure Response

This section tells the ROM what to do if communication with the Interface Module fails. It will either maintain the last value (*Hold*), or turn the relay to a predetermined energized or de-energized state (*On/Off*).

Output Test

This function allows you to change the state of each relay. After clicking *Output Test*, use the check boxes to select the desired relay and press *Update Output*. A checked box energizes the corresponding relay.

Commit/Cancel Buttons

Click *Commit* when you are finished selecting parameters to save the settings to memory. *Cancel* ends your configuration without saving changes.

Figure 30. ROM Configuration Web Page

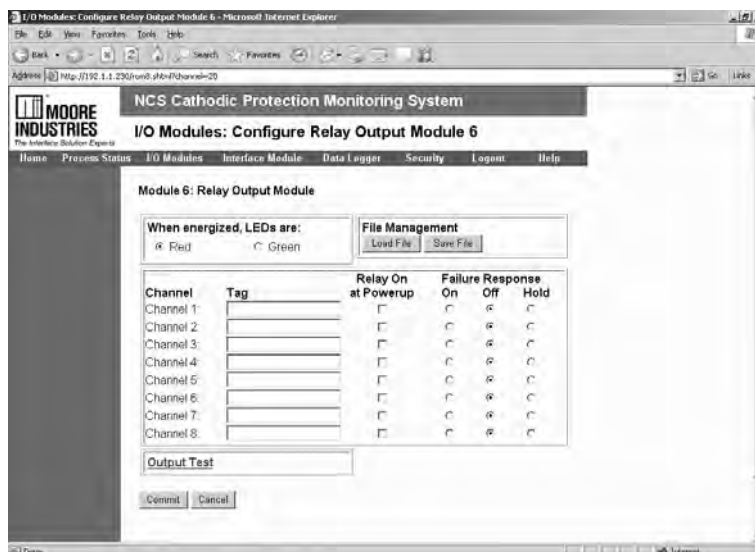

CPMS – ROM

Cathodic Protection Monitoring System
Relay Output Module

Figure 31. Terminal Designations of CPMS I/O Modules

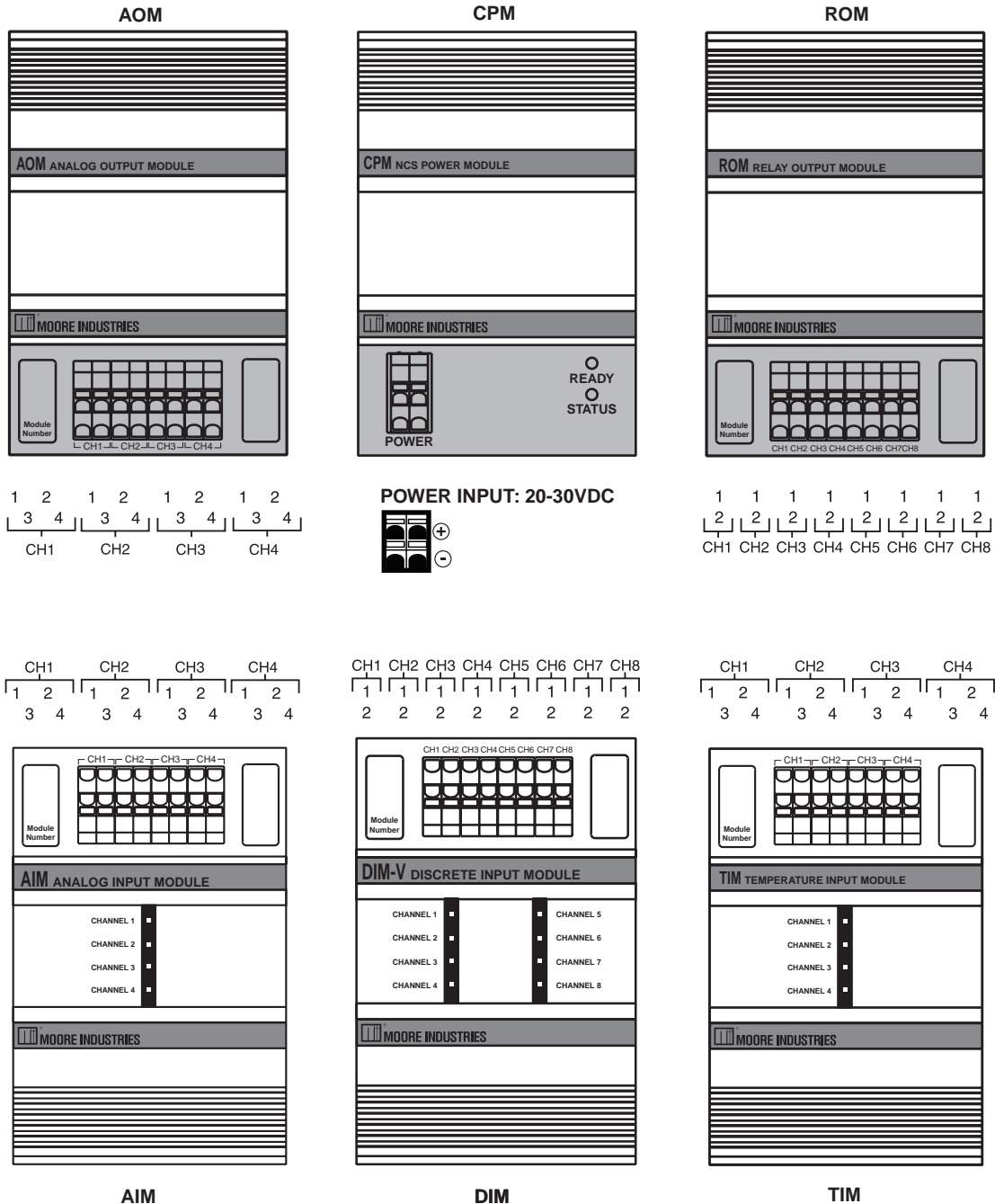

Loading a Custom Curve File

There are two ways in which a custom curve can be loaded into the CPMS for use with the Current Input Module and external input modules configuration pages. In order to create a Comma Separated Value (.csv) file, you will need either Microsoft Excel® or other similar spreadsheet program, (refer to Figure 32) or a text editor (refer to Figure 33).

1. Open a new sheet in Microsoft Excel®. Using column A as your X data, and column B as your Y data observe the following scheme:

Column A: The X data must be a monotonically increasing sequence (i.e. each value must be greater than the previous value in the sequence).

Column B: The Y data may be any sequence. You may enter up to 128 X,Y pairs. All numbers must be real, signed numbers, up to 6 digits long (7 digits and higher must be translated to exponential notation) or 6 plus one decimal point. Exponent notation (in the form of 1e+010, rather than 10e9) may also be used, but it will be translated to the full value (i.e. 10e9 = 10000000000) and thus must not represent a number higher than Xe37. Numbers represented as Xe38 and above will produce errors.

After entering your values, simply save as a .csv file.

2. Observing the same rules, you can also use a text editor to create your .csv file in the following manner: The file must be saved with a .csv extension. The .csv file is then transferred to the CPMS's *cfg* directory.

To configure the AIM with the custom curve, perform the following:

1. From the configuration page for the channel requiring the custom curve, click *Load .csv*.
2. The *Load Custom Curve* window will appear. Select the file you created from the list and click *Load*.
3. The *Load Custom Curve* window will disappear. Check the *Enabled* box in the Custom Curve section of the configuration page and click *Commit*.

Figure 32. Comma Separated Value file (Microsoft Excel® Spreadsheet)

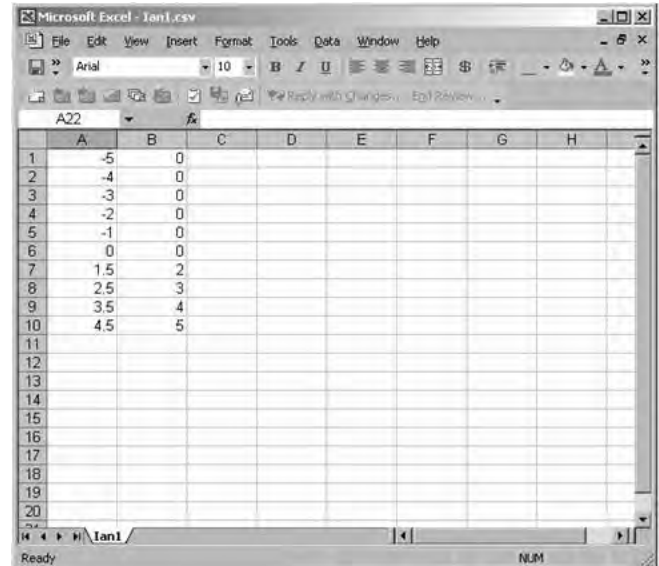

Figure 33. Comma Separated Value file (text editor)



File Management

This section describes the File Management capability which enables you to save, and apply, saved configurations to numerous units.

To Save a File

Set the parameters you wish to save as a file and click *Commit*. Once you have done this, click the *Save File* button and assign a name to the file. In the window that appears, click the *Save* button.

To Load a File

To retrieve or reapply a saved configuration, click the *Load File* button and select the correct file name. In the window that appears, click the *Load* button.

Deleting Saved Configurations

To delete a previously saved configuration, access your system's FTP site. Open the *cfg* folder and then select, and delete, the files you no longer need.

MODBUS RTU / TCP Support

Each CPMS module is designed to be accessed using MODBUS communication. The section below supplies all of the information necessary to reference the MODBUS register map and program a generic MODBUS RTU master.

MODBUS RTU Support

The two RS-485 ports on the CPMS act as independent MODBUS RTU slaves or masters. The MODBUS registers allow access to process variable data and status information. See Tables 9 and 10 for a complete list of available MODBUS registers.

In order to access the CPMS MODBUS registers via MODBUS RTU, you must ensure proper configuration of the MODBUS RTU port and the MODBUS master.

In the configuration interface, the MODBUS RTU port(s) must be configured with the MODBUS slave address, baud rate, parity, character timeout and response delay.

To configure a MODBUS Master, first you must configure the MODBUS slave address of the connected CPMS MODBUS port. You will also need to set the master with the same baud rate and character timeout as the CPMS module. Finally, the MODBUS register addresses to be polled and poll scheduling information will need to set. Refer to the *MODBUS Configuration* portion of this manual for configuration information.

To use the CPMS as a MODBUS master, refer to the *Configuring the CPMS as a MODBUS Master* section of the user's manual.

MODBUS TCP Support

MODBUS TCP is supported according to the document, *Open MODBUS/TCP Specification*, release 1.0, 29March1999, Schneider Electric. The MODBUS registers allow access to process variable data and status information. See Tables 9 and 10 for a complete list of available MODBUS registers.

In order to access the CPMS MODBUS registers via MODBUS TCP, the MODBUS TCP master must be configured with the IP address of the CPMS module to act as the polled slave device, the MODBUS register

addresses to be polled in the CPMS module and the polling schedule information. Refer to the *CPMS Web Server* portion of this manual for configuration information.

Accessing Real-Time Data via MODBUS RTU / TCP

Reading Primary Variables

Process variables are read using MODBUS function code 3 or 4. Each 32-bit floating-point process variable will be mapped to two MODBUS registers; the lower numbered MODBUS register will hold the least-significant-word (LSW), and the higher numbered MODBUS register will hold the most-significant-word (MSW) of the 32-bit value.

For MODBUS Masters or clients that support swapped floating point, the CPMS provides a setting to change the default word order using the *MODBUS properties* page of the web server.

Reading Device Status

Diagnostic data is read using MODBUS function codes

1 to 4. Each 16-bit status register will be one MODBUS integer register, accessible using function codes 3 or 4. When using function codes 1 or 2, the 16 status register bits are mapped to 16 consecutive cells, with the status register's least-significant-bit in the lowest addressed cell.

Communicating with Connected Modules

At startup, the CPMS will perform an initialization sequence to detect all connected I/O modules. If it recognizes the connected device, it will mark the module as active in preparation for data scanning. After detecting connected modules, the CPMS will begin continuous polling for the present process variable and status of each module. The returned data is stored locally by the CPMS for access by the configuration software, MODBUS RTU master or MODBUS TCP server or web server. The CPMS continuously polls all connected I/O modules.

CPMS

Cathodic Protection
Monitoring System

Scaled Primary Variables

In addition to being accessible as floating point data, the Primary Variables can be accessed as scaled integers. The scaled integer primary variable data in each NCS I/O module occupies four consecutive integer registers. Data in module 1 occupies registers 601 through 604. Module 2 occupies registers 605 through 608. See Table 9 for MODBUS registers. Regardless of the I/O data type, floating point or discrete, an I/O module occupies its four allotted integer registers.

Ambient Temperature

A range of integer registers starting at 701 contains the ambient temperature variables for the TIM (Temperature Input Module). Four consecutive registers are dedicated to each module position, regardless of whether the module is a TIM. If there is a TIM in position 2, its four integer scaled ambient temperature variables will appear at registers 705, 706, 707 and 708.

Data Conversion

Integer data is unsigned. The “zero” (input/output lower range value) is mapped to integer 4096 (HEX 0x1000) and the “full” (input/output upper range value) is mapped to integer 61,439 (HEX 0xEFFF). This range allows an integer representation of the entire range with some additional room for out-of-range values. For process variables, the zero and full values are taken from the Lower Range Value and Upper Range Value unless scaling is enabled. If scaling is enabled, they are taken from the Lower Scaled Value and Upper Scaled Value.

For ambient temperature variables in the TIM, the ambient operating range, -40°C (Lower Range Value) to +85°C (Upper Range Value) is scaled from 4096 to 61,439. Refer to Example 1 for an example of floating point value to integer value conversion.

Scaling Example

As an example, assume that the integer value of a temperature input is 16,862, located in MODBUS register 40,601. In order to see the floating point representation of that value, located in MODBUS register 40,001, use the lower and upper range values given Example 1.

Example 1. *Data Conversion Example*

$$\left(\frac{\text{Integer} - 4096}{57,343} \right) \left(\frac{\text{UpperRange Value} - \text{LowerRange Value}}{\text{Value}} \right) + \text{LowerRange Value}$$
$$\left(\frac{16,862 - 4096}{57,343} \right) \left(\frac{1760 - (-400)}{\text{Value}} \right) + (-400)$$

Note: The values used in this calculation are obtained as follows from the *Data Conversion* section of this manual:

4096: Zero range integer value

57,343: Difference between zero and full range integer values. 61,439 (full range integer value) and 4096.

1760: Upper value of temperature input range.

-400: Lower value of temperature input range.

After running the calculations, the floating point representation of 16,862 should be 80.871.

Register Addressing

The data in each NCS interface module is designed to be accessed using MODBUS communication. The section below supplies all of the information necessary to reference the MODBUS register map.

Table 9.A CPMS Specific Registers

Variable Name	Register Reference	Number of MODBUS Registers	Function Code	Data Type
OIM1, Channel 1	1	1	3 or 4	Float
OIM1, Channel 2	3	1	3 or 4	Float
OIM1, Channel 3	5	1	3 or 4	Float
OIM1, Channel 4	7	1	3 or 4	Float
OIM2, Channel 1	9	1	3 or 4	Float
OIM2, Channel 2	11	1	3 or 4	Float
OIM2, Channel 3	13	1	3 or 4	Float
OIM2, Channel 4	15	1	3 or 4	Float
DI Channel 1	161	1	1 or 2	Discrete
DI Channel 2	162	1	1 or 2	Discrete
DI Channel 3	163	1	1 or 2	Discrete
DI Channel 4	164	1	1 or 2	Discrete
Interface Module Discrete Primary Variable Block	521	1	3 or 4	Integer
OIM1, Channel 1	600	1	3 or 4	Unsigned Integer
OIM1, Channel 2	601	1	3 or 4	Unsigned Integer
OIM1, Channel 3	602	1	3 or 4	Unsigned Integer
OIM1, Channel 4	603	1	3 or 4	Unsigned Integer
OIM2, Channel 1	604	1	3 or 4	Unsigned Integer
OIM2, Channel 2	605	1	3 or 4	Unsigned Integer
OIM2, Channel 3	606	1	3 or 4	Unsigned Integer
OIM2, Channel 4	607	1	3 or 4	Unsigned Integer

Notes:

OIM is the on-board input module i.e. 4-20mA, CIM or VIM based on your specific mode

Table 9.B Process Data

Variable Name	Register Reference	Number of MODBUS Registers	Function Code	Data Type
Primary Variable	$1 + 8(M - 1) + 2(C - 1)$	2	3, 4, 6, or 16	Float
Primary Variable Register	$601 + 4(M - 1) + (C - 1)$	1	3, 4, 6, or 16	Unsigned Integer
Ambient Temperature (TIM only)	$201 + 8(M - 1) + 2(C - 1)$	2	3 or 4	Float
Ambient Temperature Register (TIM only)	$701 + 4(M - 1) + (C - 1)$	1	3 or 4	Unsigned Integer
Discrete Primary Variable Block	$500 + M$	1	3, 4, 6, or 16	Integer
Discrete Primary Variable	$8(M - 1) + C$	1	1-6, 15 or 16	Discrete

CPMS

Cathodic Protection
Monitoring System

Table 9.C Module/Channel Status

Variable Name	Register Reference	Number of MODBUS Registers	Function Code	Data Type
Base Fail Register	2001	1	3 or 4	Integer
Base Fail Flags	2015 + M	1	1 or 2	Discrete
Module Fail Register	2002	1	3 or 4	Integer
Module Fail Flags	2031 + M	1	1 or 2	Discrete
Channel Status Register	2002 + 4(M - 1) + C	1	3 or 4	Integer
Channel Status Flags	2048 + 64(M - 1) + 16(C - 1) + B	1	1 or 2	Discrete
Discrete Module Status Register	2003 + 4(M - 1)	1	3 or 4	Integer
Discrete Module Status Flags	2048 + 64(M - 1) + B	1	1 or 2	Discrete

Table 9.D System Status

Variable Name	Register Reference	Number of MODBUS Registers	Function Code	Data Type
Interface Module Status Register	2000	1	3 or 4	Integer
System HW/SW Fault Status	4001	1	3 or 4	Integer
File System Status	4002	1	3 or 4	Integer
Configuration Status	4003	1	3 or 4	Integer
Data Logger Status	4004	1	3 or 4	Integer
System Time Status Register	4005	1	3 or 4	Integer
ISaGRAF Status Register	4007	1	3 or 4	Integer
MODBUS Master Status	4008	1	3 or 4	Integer
MODBUS Peer to Peer Status	4009	1	3 or 4	Integer
GPS Status	4010	1	3 or 4	Integer
Interface Module Status Flags	2000 + B	1	1 or 2	Discrete
System HW/SW Fault Flags	4001 + B	1	1 or 2	Discrete
File System Status Flags	4017 + B	1	1 or 2	Discrete
Configuration Status Flags	4033 + B	1	1 or 2	Discrete
Data Logger Status Flags	4049 + B	1	1 or 2	Discrete
System Time Status Flags	4065 + B	1	1 or 2	Discrete
ISaGRAF Status Flags	4097 + B	1	1 or 2	Discrete
MODBUS Master Status Flags	4113 + B	1	1 or 2	Discrete
MODBUS Peer to Peer Status Flags	4129 + B	1	1 or 2	Discrete
GPS Status Flags	4145 + B	1	1 or 2	Discrete

Table 9.E Miscellaneous

Variable Name	Register Reference	Number of MODBUS Registers	Function Code	Data Type
Float Utility Variable N	3000 + 2N – 1 (N from 1 to 500)	2	3, 4, 6 or 16	Float
Integer Utility Variable N	3000 + N (N from 1 to 1000)	1	3, 4, 6 or 16	Integer
Discrete Utility Variable N	3000 + N (N from 1 to 500)	1	1, 2, 5 or 15	Discrete
Serial Number (upper)	1900	1	3 or 4	Integer
Serial Number (lower)	1901	1	3 or 4	Integer
Version major	1902	1	3 or 4	Integer
Version minor	1903	1	3 or 4	Integer
Version build	1904	1	3 or 4	Integer
Year	1905	1	3 or 4	Integer
Month	1906	1	3 or 4	Integer
Date	1907	1	3 or 4	Integer
Hour	1908	1	3 or 4	Integer
Minute	1909	1	3 or 4	Integer
Second	1910	1	3 or 4	Integer
Milliseconds	1911	1	3 or 4	Integer
Arbitrary Second Counter	1912	1	3 or 4	Integer
GPS Is Fixed	1913	1	3 or 4	Integer
GPS Number of Satellites	1914	1	3 or 4	Integer

Notes:

1. Analog inputs 1-4 belong to Module 1.
2. Analog inputs 5-8, if present, belong to Module 2.
3. If 4 analog inputs are present on the CPMS, any externally attached modules start at Module Number 2 .
4. If 8 analog inputs are present, attached modules start at Module Number 3.
5. DI is an abbreviation for Discrete Input.
6. OIM is the on-board input module i.e. 4-20mA (Current Input Module), CIM (Cathodic Input Module) or VIM (Voltage Input Module) based on your specific model.
7. Each set of current or cathodic inputs in the CPMS is treated as a module.
8. Register numbers remain the same regardless of which on-board input module is installed.
9. In Register Reference:
 - M** represents module position (1-8);
 - C** represents channel number (1-4);
 - B** represents bit position (0-15) within the register.
10. When using function codes 3, 4, 6 or 16, one discrete primary variable is delivered per MODBUS register, with a non-zero integer value representing logic.

CPMS

Cathodic Protection Monitoring System

The following tables 10A-10J apply only to units with Firmware 4.5 or newer. Refer to Appendix A for older models.

Table 10.A. CPMS System Status Summary Register Bit Positions

BIT Position	Description
0	An error occurred in one of the attached I/O modules; Refer to Tables 11-14
1	System HW or SW Fault detected
2	Problem with the Filesystem; Refer to Table 10.B
3	Problem with station configuration; Refer to Table 10.C
4	Problem with the Data Logger; Refer to Table 10.D
5	Problem with the Time Subsystem; Refer to Table 10.E
6	Problem with the Battery Backup Module; Refer to Table 10.F
7	An ISaGRAF error has occurred; Refer to Table 10.G
8	An error has occurred in the MODBUS Master Subsystem; Refer to Table 10.H
9	An error has occurred in the MODBUS Peer-to-Peer Subsystem; Refer to Table 10.I
10	There is an issue with the GPS Subsystem; Refer to Table 10.J

Table 10.B File System Status Register Bit Positions

BIT Position	Description	Troubleshooting
0	File system initialization error. Indicates that the state of the file system cannot be determined. Depending on the type of error, the NCS may attempt to automatically format the file system.	
1	New file system. Indicates that the file system has been formatted. Normally, this is only performed once at the initial system startup. However, an automatic format can occur if the file system becomes corrupted.	Cycle power, and contact Customer Support if the condition does not clear itself.
2	The file system is full	Too many configurations, custom curves, or large ISaGRAF resources are in the filesystem. Use FTP to delete the contents of the cfg and hds folders.

Table 10.C Configuration Status Register Bit Positions

BIT Position	Description	Troubleshooting
0	Missing system configuration file	Use NAC Client to reconfigure network settings, and then reconfigure MODBUS.
1	Missing or corrupted password file or password jumper was detected. Default password file loaded.	Cycle power to clear the error
2	File containing expected module types was not found	On the System Status web page, click the "Accept Module Types" button.
3	Detected module types do not match those which are expected	
4	Channel tag file not found	Configure any channel to create the tags file.
5	Custom engineering units (EGU) file not found	Configure any channel to create the EGU file

Table 10.D Data Logger Status Register Bit Positions

BIT Position	Description	Troubleshooting
0	Data Logger could not be initialized	The logger configuration file is either missing or was corrupted. Click Update on the Configure Data Logger web page
1	Data Logger failed to restore records from non-volatile RAM	There was a problem with non volatile storage. Check the "Clock Battery Fail" bit in the System Time Substatus register

Table 10.E Time Subsystem Status Register Bit Positions

BIT Position	Description	Troubleshooting
0	Clock battery failed, or clock mode failed (replace the clock battery or the clock module).	Replace the clock battery or the clock module.
1	SNTP system communications error.	Check the network and Time Server configuration settings
		Verify that the system can be accessed by navigating to the webserver
		This error can occur if too many inbound connections are made to the system, preventing it from making an outbound connection
2	Could not resolve time server hostname.	There is an error in the Time Server field on the System Time webpage
3	System timed out waiting for response from time server.	Verify the IP address of the time server being used, and that it accepts SNTP queries
4	System time has been set to default.	Reboot and set the clock.

Table 10.F Battery Backup Module Status Register Bit Positions

BIT Position	Description	Troubleshooting
0	The Battery Backup Module's battery is bad	Verify physical connection between BBM and NCS Interface Module
1	Input power failed, running on BBM power	The BBM has detected (and has reported to the Interface Module) that mains power has been lost. Restore power before the battery is completely discharged.

If there is no BBM connected, then both bits will be set. In this case, the following UI message will be displayed:
"(00/01) The Battery Backup Module is not present."

CPMS

Cathodic Protection
Monitoring System

Table 10.G ISaGRAF Status Register Bit Positions

BIT		
Position	Description	Troubleshooting
0	ISaGRAF has caused a system fault.	Reboot and check if the condition clears itself.
1	Reserved	N/A
2	Reserved	N/A
3	Reserved	N/A
4	I/O Wiring module type mismatch.	The ISaGRAF resource is expecting certain module types, however different modules are physically present. Either correct the resource, or install the correct modules.
5	One or more resources failed to restore retained data.	(This error is normal the first time a resource with retain variables is executed, or when the variables in the dictionary are changed. If after an ISaGRAF restart (or a reboot) the problem persists, check the "Clock Battery Fail" bit in the System Time Substatus register
6	One or more resources failed to write data.	There is not enough room left in non-volatile storage. Use the ISaGRAF webpage to "Clear Retain Variables". If the problem is not corrected after a power cycle, reduce the number of variables configured as "retained"

Table 10.H MODBUS Master Status Register Bit Positions

BIT		
Position	Description	Troubleshooting
0	MODBUS Master System Fault	Reboot and contact Customer Service if the condition does not clear itself.
1	Bad Transfer Definition (there are one or more mistakes in schedule.ini).	The schedule.ini file contains one or more syntax error. Check the "Status Details" to determine which line the error is on.
2	Timeout (one or more transfers were not responded to).	The Response Timeout Setting is too short for the combination of baud rate, query/response length, and slave response time;
		There is a network problem Check baud rates, and the address assigned to the slave; Instead of returning an Exception Response to improper queries, some slaves simply do not respond.
3	Exception Response (one or more transfers returned a MODBUS exception code).	A non-supported function code was used
		An out of range register/coil was requested
		Too many registers were requested

Use the "Status Detail" button on the MODBUS web page to determine which slave is returning the Exception Response.

Table 10.I MODBUS Peer to Peer Status Register Bit Positions

BIT Position	Description	Troubleshooting
0	Loss of a Communication Link to a Producer Station on Port 1	RS485 wiring is incomplete or incorrectly connected
		Baud rate/character format configurations for Port 1 of the stations in the Peer-to-Peer system do not match
		The producer station does not have Peer-to-Peer enabled on Port 1
1	Loss of a Communication Link to a Producer Station on Port 2	RS485 wiring is incomplete or incorrectly connected
		Baud rate/character format configurations for Port 2 of the stations in the Peer-to-Peer system do not match
		The producer station does not have Peer-to-Peer enabled on Port 2
2	Incompatible Module Types Port 1	The corresponding module in the producer station is an output module, such as an AOM in the consumer station but another AOM in the corresponding module position of the producer station
		The corresponding module in the producer station is an input module but of the wrong data type, such as an AOM (expecting floating point data) in the consumer station but a DIM (transmitting Boolean data) in the corresponding module position of the producer station
3	Incompatible Module Types Port 2	The corresponding module in the producer station is an output module, such as an AOM in the consumer station but another AOM in the corresponding module position of the producer station
		The corresponding module in the producer station is an input module but of the wrong data type, such as an AOM (expecting floating point data) in the consumer station but a DIM (transmitting Boolean data) in the corresponding module position of the producer station
4	Error in Producer Channel or Module	The input channel in the producer station corresponding to this output channel has a flag in its Channel Status register (refer to Appendix A)
		The flag in the Module Fail register of the producer station corresponding to this output channel's module position is true
		The flag in the Base Fail register of the producer station corresponding to this output channel's module position is true
5	Duplicate Slave	Check devices connected to the MODBUS network for duplicate slave addresses.

Table 10.J. GPS Status Register Bit Positions

BIT Position	Description	Troubleshooting
0	GPS System fault	Reboot and contact Customer Service if the condition does not clear itself
1	GPS System not initialized	GPS data was accessed, either by the time subsystem, or ISaGRAF, however GPS is not installed
		Check that the proper remote .ini file is installed for GPS use
2	No Response from GPS module.	The NCS should constantly be receiving data from the GPS module. If this problem persists, it could be a hardware problem. Reboot and check if the condition clears itself
3	GPS does not have a satellite fix	If other GPS error bits are present, resolve them first. / Improve antenna location
		Improve antenna location

CPMS

Cathodic Protection Monitoring System

Table 11. AIM Channel Status Register/Bit Positions

Bit Position	Description
11	Run-time Failure
10	EEPROM Failure
9	A/D Converter Failure
7	Broken wire #1-4
6	
5	
4	
3	Analog Input #1 A/D Saturated or Analog Input #2 A/D Saturated
2	Input signal of RTD/TC linearization table range or Input/Trimmed value out of custom table range
1	Channel not used
0	I/O channel failure

Table 12. TIM Channel Status Register/Bit Positions

Bit Position	Description
11	Run-time Failure
10	EEPROM Failure
9	A/D Converter Failure
8	Broken RJC
7	Broken Wire #4
6	Broken Wire #3
5	Broken Wire #2
4	Broken Wire #1
3	Analog Input A/D Saturated
2	Input Signal out of Linearized Range
1	Channel not Used
0	I/O Channel Fail

Table 13. AOM Channel Status Register/Bit Positions

Bit Position	Description
9	PV is too large
8	PV is too small
7	PV is invalid floating-point value
6	Low current error
5	Front-end reset occurred
4	FLASH failure
3	SRAM failure
2	EEPROM failure
1	Channel not used
0	I/O channel failure

Table 14. DIM and ROM Channel Status Registers/Bit Positions

Bit Position	Description
6	LED Port Error
5	Front-end reset occurred
4	FLASH failure
3	SRAM failure
2	EEPROM failure
1	Channel not used
0	I/O channel failure

Installation

Installation consists of physically mounting the unit and completing the electrical connections.

Mounting

The CPMS is designed to snap easily onto 32mm, G-type (EN50035) or 35mm Top Hat (EN50022) DIN-rails. Snap the CPMS onto the DIN-rail, then snap additional modules onto the DIN-rail to the right of the Interface Module; slide together until the DB25 connectors on the side connect completely with those to the right.

When mounting multiple units, as you would in a rack or cabinet, make sure to allow adequate vertical spacing for pivoting the units.

Making the Electrical Connections

Refer to Figure 3 for electrical connections and to associated pages of the I/O modules to be installed.

Recommended Ground Wiring Practices

Moore Industries recommends the following ground wiring practices:

- Any Moore Industries product in a metal case or housing should be grounded.
- The CPMS individual module bases are mechanically grounded when installed onto the DIN-rail. Be sure the DIN-rail is connected to a system safety earth ground before making any other connections.
- With the exception of the Ethernet connection, which may use an unshielded, twisted pair, all input signals to, and output signals from, Moore Industries' products should be wired using a shielded, twisted pair technique. Shields are to be connected to an earth or safety ground at one end only.
- The maximum length of unshielded input and output signal wiring should be 2 inches.

Note: *Some of Moore Industries' instruments can be classified as receivers (IPT2, IPX2, etc.) and some can be classified as transmitters (TRX, TRY, etc.) while some are both a receiver and a transmitter (SPA2, HIM, etc). Hence, your shield ground connections should be appropriate for the type of signal line being shielded. The shield should be grounded at the receiver and not at the signal source.*

Power Sourcing Parameters for General locations, Intrinsically Safe and Non-Incendive/Type N Applications

In accordance with IEC 1010.1 Annex H (all models), the input terminals must be connected to and/or supplied from a certified energy limiting Class 2 or a Separate Extra Low Voltage (S.E.L.V.) power supply separated from all mains by double/reinforced insulation.

CPMS

Cathodic Protection
Monitoring System

Operation

Once programmed, calibrated, installed and supplied with the correct power, the CPMS begins to operate immediately. Depending upon environmental conditions, it can be expected to operate unattended for extended periods of time.

Maintenance

Moore Industries suggests a quick check for terminal tightness and general unit condition every 6-8 months. Always adhere to any site requirements for programmed maintenance.

Customer Support

Moore Industries is recognized as the industry leader in delivering top quality to its customers in products and services. We perform a battery of stringent quality assurance checks on every unit we ship. If any Moore Industries product fails to perform up to rated specifications, call us for help. Our highly skilled staff of trained technicians and engineers pride themselves on their ability to provide timely, accurate, and practical answers to your process instrumentation questions.

Factory phone numbers are listed on the back cover of this manual.

If problems involve a particular CPMS, there are several pieces of information that can be gathered **before you call the factory** that will help our staff get the answers you need **in the shortest time possible**. For fastest service, gather the complete model and serial number(s) of the problem unit(s) and the job number of the original sale.

Appendix A

The Status Bits for newer CPMS units have been updated and changed. The following tables apply only to units with Firmware 4.4 or older and should be used instead of Tables 10A-10J in the main manual.

CPMS Module Status

The I/O status register obtained during data scanning is used to create a 16-bit status word. The status word can be read using MODBUS RTU as described earlier.

The status register bits are defined in Tables A1-A4. An error is indicated by a set bit or any combination of set bits. If none of the status register flags are true, the system is reported as OK. If one or more fault flags are true, messages are displayed indicating the faults. Next, bit positions of the fault flags in the CPMS status register appear followed by the corresponding fault message and then the fault priority.

Table A.1. CPMS Module Status Register

Bit Position	Description
15	MODBUS Master Fault
14	An ISaGRAF error has occurred (see ISaGRAF Status Register for details).
13	Not used
12	Not used
11	The file system is full.
10	Data Logger failed to restore records from non-volatile RAM.
9	The data logger could not be initialized.
8	Indicates a failure to start one or more of the network services.
7	Indicates a failure in the I/O module port.
6	Missing or corrupted password file or password jumper was detected. Default password file loaded.
5	A system time error has occurred (see System Time Status Register for details).
4	Missing system configuration file.
3	New file system. Indicates that the EIM has formatted the file system. Normally, this is only performed once at the initial system startup. However, an automatic format can occur if the file system becomes corrupted.
2	File system initialization error. Indicates that the EIM cannot determine the state of the file system. Depending on the type of error, the EIM may attempt to automatically format the file system.
1	RAM test failed. This bit is set when a read/write error occurs during the power-on RAM test.
0	Slave device error. Indicates an error in an attached I/O module (see Channel Status Registers for details).

Table A.2. System Time Status Register

Bit Position	Description
4	System time has been set to default.
3	System timed out waiting for response from time server.
2	Could not resolve time server host name.
1	SNTP system communications error.
0	Clock battery failed, or clock mode failed (replace the clock battery or the clock module).

Table A.3. *ISaGRAF Status Register*

Bit Position	Description
6	One or more resources failed to write data.
5	One or more resources failed to restore retained data.
4	I/O Wiring module type mismatch.
0	ISaGRAF has caused a system fault.

Table A.4. *MODBUS Master Status Register*

Bit Position	Description
3	Exception Response (one or more transfers returned a MODBUS exception code).
2	Timeout (one or more transfers were not responded to).
1	Bad Transfer Definition (there are one, or multiple, mistakes in schedule.ini).
0	System Fault.

Appendix B

Establishing a PPP Connection

To establish configuration access to the CPMS's PC port via PPP programming, proceed with the instructions below. Instructions will vary depending upon which version of the Windows® operating system is being used. Please refer to the appropriate section for your system.

Note:

You must have Administrator level permissions in order to configure a PPP connection.

Windows® XP Professional

1. Access your PC's *Start* menu, then select *Control Panel* and finally *Network Connections*.
2. *Select *Create a new connection*, then click *Next*.
 - a. Select *Set up an advanced connection* and click *Next*.
 - b. Select *Connect directly to another computer* and click *Next*.
 - c. Select *Guest* as the role the Windows® PC should play in the connection, then click *Next*.
 - d. Enter a name for this connection and click *Next*.
 - e. Select the PC serial communication (COM) port to which the CPMS is connected and click *Next*.
 - f. Select the appropriate connection availability level for this connection and click *Next*.
 - g. Click *Finish*.
3. On the *Connect* window, click the *Properties* button.
 - a. On the *Properties* window, ensure that the correct COM port is displayed then click the *Configure* button on the *General* window.

Set the maximum speed (bps) that corresponds to the baud rate in the *pcport.ini* file (default is 57600). Then, click *OK*.

- b. Select the *Networking* tab and highlight *Internet Protocol (TCP/IP)* and click *Properties*. At the next window, click the *Use the following IP address* button and enter an address (ensure that you do not assign the CPMS default address of *http://192.168.2.100*). The address assigned must be in the same subnet as the address of the PPP port for a successful connection. Therefore, you may assign an address such as 192.168.2.xxx, where xxx is a valid entry from 1 to 254, but not equal to 100. An example of a valid address would be 192.168.2.111. You may leave the DNS server address blank. Click *OK*. Click *OK* again in the properties window.

- c. Select the appropriate settings in the *Options*, *Security* and *Advanced* windows.

4. Enter the *User name* (default is *root*) and *Password* (default is *password*) and click *Connect*.

5. Open Internet Explorer and enter the CPMS address to open the CPMS Home Page.

Windows® 2000 Professional

1. Access your PC's *Start* menu, then select *Control Panel* and finally *Network Connections*.
2. *Start the *New Connection Wizard*; click *Next*.
 - a. Select *Connect directly to another computer* and click *Next*.
 - b. Select *Guest* as the role the Windows® PC should play in the connection and click *Next*.
 - c. Select the PC serial communication (COM) port to which the CPMS is connected and then click *Next*.
 - d. Select the appropriate connection availability level for this connection and click *Next*.
 - e. Enter a name for this connection and click *Next*, then click *Finish*.
3. On the *Connect* window, click the *Properties* button.
 - a. On the *Properties* window, select the appropriate communication port and click the *Configure* button on the *General* window.

CPMS

Cathodic Protection Monitoring System

Set the maximum speed (bps) corresponding to the baud rate specified in the *pcport.ini* file (default is 57600). Then, click *OK*.

- b. Select the *Networking* tab.
- c. Select the *Internet Protocol (TCP/IP)* component of the connection.
- d. Click the *Properties* button.

Select Use the following IP address then enter the IP address to be used for the PC portion of the connection. The IP address you select ***must*** differ from the CPMS default address which is *http://192.168.2.100*. The address assigned must be in the same subnet as the address of the PPP port for a successful connection. Therefore, you may assign an address such as 192.168.2.xxx, where xxx is a valid entry from 1 to 254, but not equal to 100. An example of a valid address would be 192.168.2.111. You may leave the DNS server address blank. Click *Ok*. Click *Ok* at the next prompt.

4. Enter the *User name* (default is *root*) and *Password* (default is *password*) and click *Connect*.

5. Open Internet Explorer and go to the CPMS Home Page using *http://192.168.2.100*, the default PPP address for the CPMS.

Note:

When connecting the CPMS using PPP, the IP address in the default PPP file (192.168.2.100) must be used. When connecting to the CPMS over Ethernet, the address set using NAC Client Software must be used.

Warranty Disclaimer

Moore Industries ("The Company") makes no express, implied or statutory warranties (including any warranty of merchantability or of fitness for a particular purpose) with respect to any goods or services sold by the company. The company disclaims all warranties arising from any course of dealing or trade usage, and any buyer of goods or services from the company acknowledges that there are no warranties implied by custom or usage in the trade of the buyer and of the company, and that any prior dealings of the buyer with the company do not imply that the company warrants the goods or services in any way.

Any buyer of goods or services from the company agrees with the company that the sole and exclusive remedies for breach of any warranty concerning the goods or services shall be for the company, at its option, to repair or replace the goods or services or refund the purchase price. The company shall in no event be liable for any consequential or incidental damages even if the company fails in any attempt to remedy defects in the goods or services, but in such case the buyer shall be entitled to no more than a refund of all monies paid to the company by the buyer for purchase of the goods or services.

Any cause of action for breach of any warranty by the company shall be barred unless the company receives from the buyer a written notice of the alleged defect or breach within ten days from the earliest date on which the buyer could reasonably have discovered the alleged defect or breach, and no action for the breach of any warranty shall be commenced by the buyer any later than twelve months from the earliest date on which the buyer could reasonably have discovered the alleged defect or breach.

Return Policy

For a period of thirty-six (36) months from the date of shipment, and under normal conditions of use and service, Moore Industries ("The Company") will at its option replace, repair or refund the purchase price for any of its manufactured products found, upon return to the Company (transportation charges prepaid and otherwise in accordance with the return procedures established by The Company, to be defective in material or workmanship. This policy extends to the original Buyer only and not to Buyer's customers or the users of Buyer's products, unless Buyer is an engineering contractor in which case the policy shall extend to Buyer's immediate customer only. This policy shall not apply if the product has been subject to alteration, misuse, accident, neglect or improper application, installation, or operation. THE COMPANY SHALL IN NO EVENT BE LIABLE FOR ANY INCIDENTAL OR CONSEQUENTIAL DAMAGES.

To return equipment to Moore Industries for repair, follow these four steps:

1. Call Moore Industries and request a Returned Material Authorization (RMA) number.

Warranty Repair –

If you are unsure if your unit is still under warranty, we can use the unit's serial number to verify the warranty status for you over the phone. Be sure to include the RMA number on all documentation.

Non-Warranty Repair –

If your unit is out of warranty, be prepared to give us a Purchase Order number when you call. In most cases, we will be able to quote you the repair costs at that time. The repair price you are quoted will be a "Not To Exceed" price, which means that the actual repair costs may be less than the quote. Be sure to include the RMA number on all documentation.

2. Provide us with the following documentation:
 - a) A note listing the symptoms that indicate the unit needs repair
 - b) Complete shipping information for return of the equipment after repair
 - c) The name and phone number of the person to contact if questions arise at the factory
3. Use sufficient packing material and carefully pack the equipment in a sturdy shipping container.
4. Ship the equipment to the Moore Industries location nearest you.

The returned equipment will be inspected and tested at the factory. A Moore Industries representative will contact the person designated on your documentation if more information is needed. The repaired equipment, or its replacement, will be returned to you in accordance with the shipping instructions furnished in your documentation.



United States • info@miinet.com
Tel: (818) 894-7111 • FAX: (818) 891-2816
Australia • sales@mooreind.com.au
Tel: (02)8536-7200 • FAX: (02) 9525-7296

Demand Moore Reliability

www.miinet.com

BeNeLux • info@mooreind.eu
Tel: 03/448.10.18 • FAX: 03/440.17.97

China • sales@mooreind.sh.cn
Tel: 86-21-62491499 • FAX: 86-21-62490635
United Kingdom • sales@mooreind.com
Tel: 01293 514488 • FAX: 01293 536852